

# Tutorial 1

## Getting Started

### Objective

The following tutorial is a step-by-step introduction to the basics of SimulationX. You will first get an overview of the graphical user interface (GUI) with the help of an example model which you can open on your computer. In the second part, you will learn in seven steps how to create a simple model as the basis for the third part explaining in eleven steps how to extend and modify existing models (including post-processing).

- Introduction to the graphical user interface
- Working with existing example models
- Creating your own model
- Running a simulation
- Extending and modifying existing models and parameters
- Viewing results
- Post-processing

### Prerequisites

The following explanations and screenshots are based on the default settings of a newly installed trial version of SimulationX Professional Edition. You can reproduce all further steps with this version on your screen.

**Part I:** If you are using a commercial license, make sure to have the libraries *MBS Mechanics (3D)* and *Hydraulics* installed. Otherwise, simply read through Part I or view the sample model with the *Viewer Edition*.

**Parts II and III:** Apart from the *Basic Module*, no other modules are required. The models in Part II and III can also be created with the *Student Edition*. The *Viewer* and *Student Editions* are both available for free and can be downloaded in the Customer Center ([www.simulationx.com/customer-center](http://www.simulationx.com/customer-center)).

To change the edition, go to: *Extras* → *Options* → *Licensing*

### Used symbols



Left mouse button



Right mouse button



Middle mouse button





Mouse wheel

# I. Graphical User Interface (GUI)

Upon installing SimulationX on your computer for the first time, the following window appears after the first start. The *Sample Browser* provides a comprehensive collection of sample models from different applications and domains.

Here, you can choose the model to be loaded by double-clicking or pressing *Open* once selected.

To show the examples of the multi-body mechanics domain, select *Mechanics (MBS)* in the *Sample Browser's* tree view. Double-click  on *Bucket Cylinder Hydraulics* and close the *Sample Browser* by pressing the button *Close* . (You can open the *Sample Browser* later on again by clicking  on an element in the library bar, selecting *Samples...*, and the *Sample Browser* opens with a pre-selected sample model containing the selected element.)

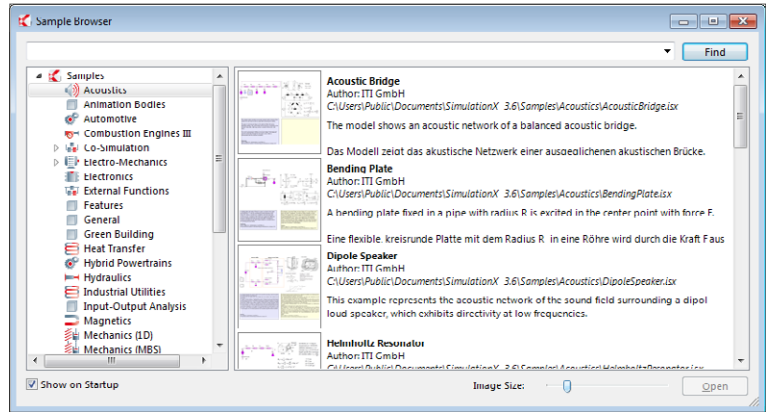

Fig. 1: *Sample Browser* with examples from SimulationX Professional Edition

The following view (with default GUI of SimulationX) and a result window appears on your screen:

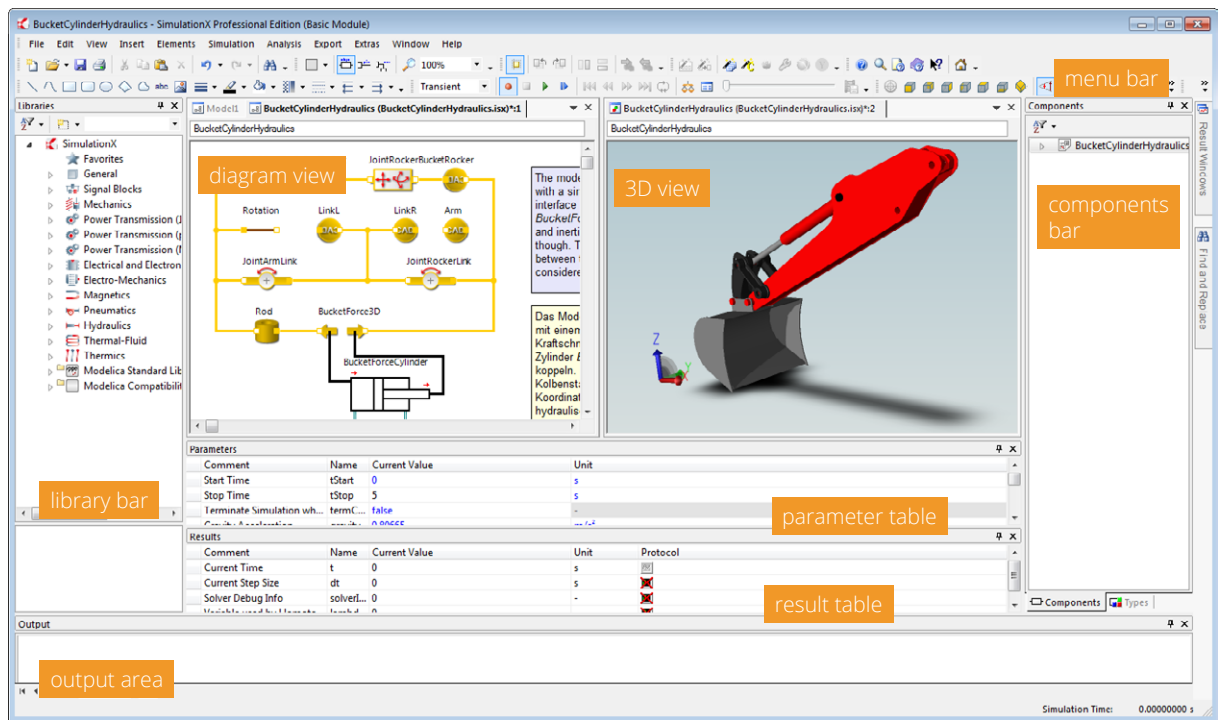



Fig. 2: Default GUI of SimulationX Professional Edition with a model (Bucket Cylinder Hydraulics) from the SimulationX *Sample Browser*

**Menu bar:** Provides tools to create models and to control the simulation.

**Library bar:** Provides access to the element types installed and grouped into different topical libraries in a hierarchical order.

**Output area:** Displays notifications, warning messages and errors. The content of the output area can be saved, exported as text and printed.

**Parameter table, result table and the components bar:** Contains the properties of your model and the results displayed. (In order to have values displayed in the parameters and result tables as shown in figure 2, click  on an element in the diagram view).

**Diagram view:** Shows the logical structure of the simulation model. In order to create a system model, model elements are connected with each other through connection lines. Additional information, such as graphical elements and text, can also be added.

**3D view:** Shows a three-dimensional visualization of the model. Some libraries (e.g. Mechanics MBS) allow you to build models also interactively in 3D. For the navigation in the 3D view and diagram views, see the table below.

Table 1: Hotkeys for the navigation in the diagram and 3D view

	Action	Hotkey
Diagram view	Move model view	Hold  + drag
	Zoom model view	Ctrl +
3D view	Rotate model view	Hold  + drag
	Move model view	Shift + hold  + drag
	Zoom model view	Ctrl + hold  + drag alternatively:

**Result window:** Shows selected results in a diagram. Values can be read out and further analyses of the simulation results can be performed.

Figure 3 shows the principal structure of a network model consisting of model elements from different libraries and physical domains. Different kinds of connections link these model elements through specific connectors.

For performing your first simulation, press (Start) in the menu bar. You then see the results in the result window (see figure 4), the effects in the 3D view and the current simulation time in the bottom right corner.

Close the model by clicking on the tab of the sample model either in the diagram (see figure 5) or 3D view and select *Close Model*. When asked whether you want to save changes, select *No*.

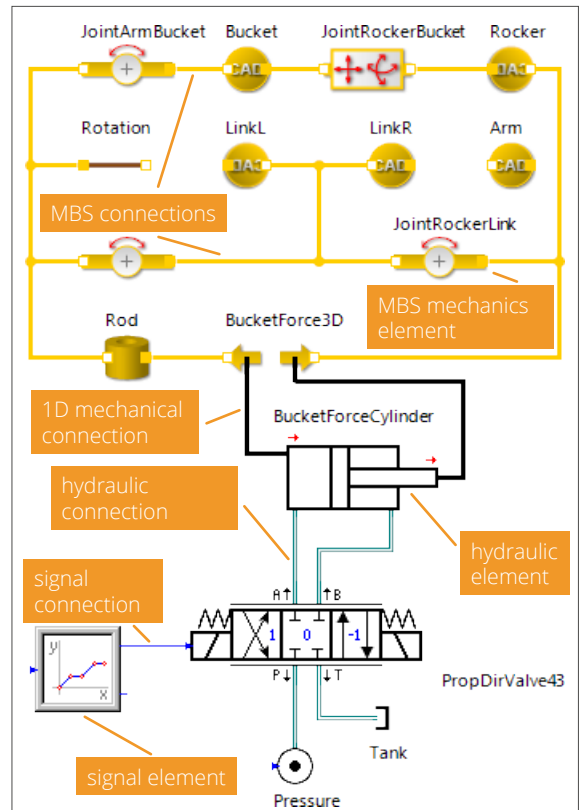

Fig. 3: Complete diagram view of the model shown in figure 2

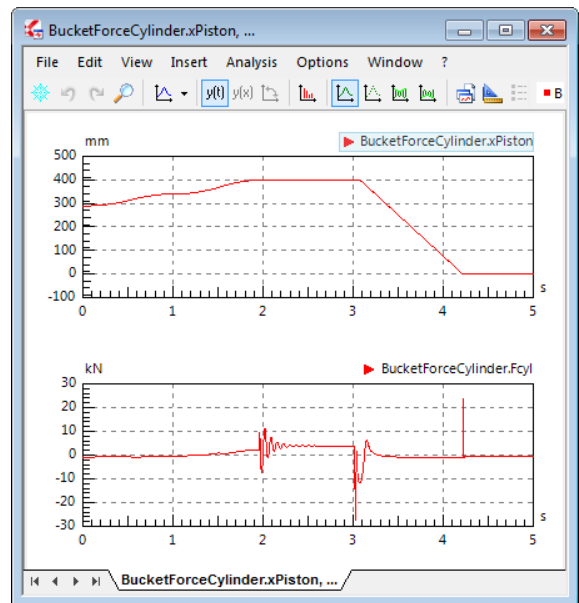

Fig. 4: Result window of the model shown in figure 2 with cylinder stroke over time (top) and cylinder force over time (bottom)

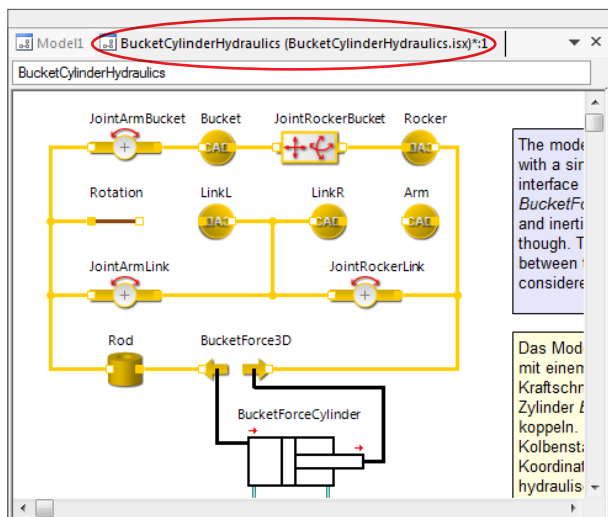





Fig. 5: Tabulator of the model in the diagram view

## II. Creating a simple model

In this chapter, you will learn about the basic structure of a network model as well as setting and changing parameters while creating a simple model of a one-mass oscillator. Furthermore, you will run a simulation and evaluate the results in a graphical result window.

### 1 Creating a model file

Click  the button *New*  in the menu bar or go to *File* → *New*. A new, empty diagram view appears. (To open an existing file, click the button *Open*  in the menu bar or *File* → *Open...*)

### 2 Dragging model elements into the diagram view

Go to *Mechanics* → *Linear Mechanics* in the library bar. Click  on *Spring*, hold the mouse button and drag the element into the diagram view. Release the mouse button.

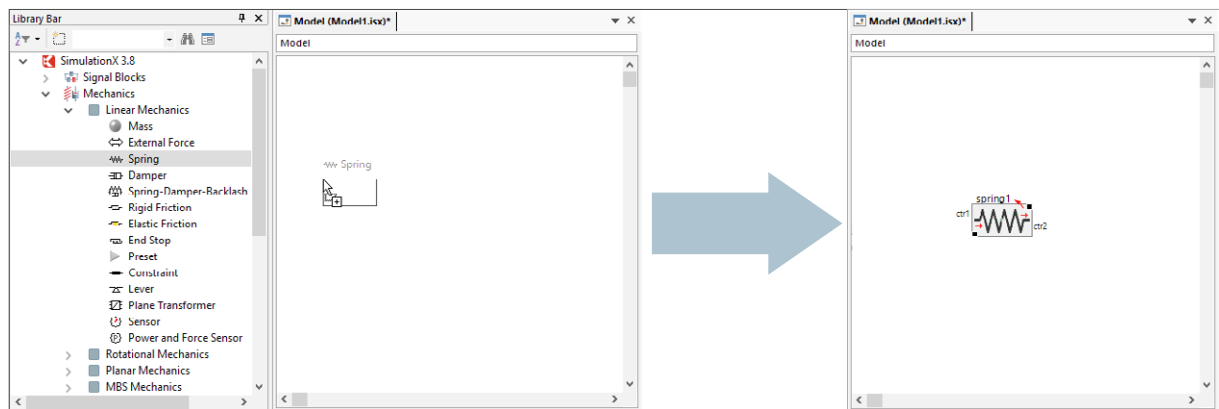





Fig. 6: Placing an element from the library bar in the diagram view by drag and drop

For information about a model element's physics, click  on *Direct Help* in the menu bar. The cursor will change to . Click  on *spring1* in the diagram view or on *Spring* in the library bar. A window will pop up with detailed information about the model element *Spring*. Close the Help with  (*Close*) to proceed with the tutorial.



Now, drag the element *Mass* from the library *Linear Mechanics* in the diagram view and drop it there. Your diagram view should look as follows:



Fig. 7: Diagram view with two unconnected model elements (*Spring* and *Mass* from the library *Linear Mechanics*)

### 3 Connecting elements

In order for the elements to be able to interact with each other, they have to be linked through connections. Activate  (*Pin Labels*) in the menu bar to display the names of the connectors in the diagram view.

Place the cursor over *ctr2* (connector 2) of *spring1*. The connector turns red and the cursor changes to . Press , hold the mouse button and drag the connection towards *ctr1* of *mass1* as shown in figure 8.

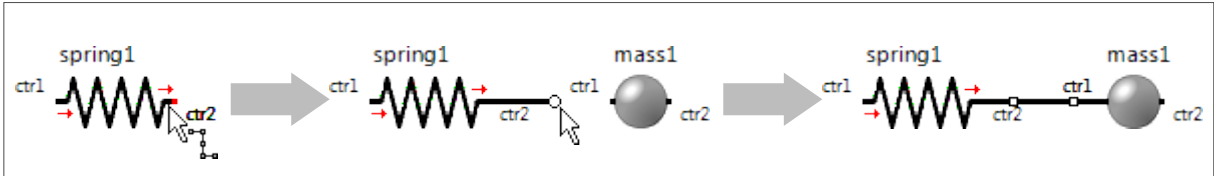

Fig. 8: Connecting *spring1* and *mass1*

Now, place a model element of type *Damper* from *Mechanics* → *Linear Mechanics* in the diagram view. Connect the model element *damper1* with the existing structure as shown in figure 9. You will notice that you can also connect a connector with an existing connection.

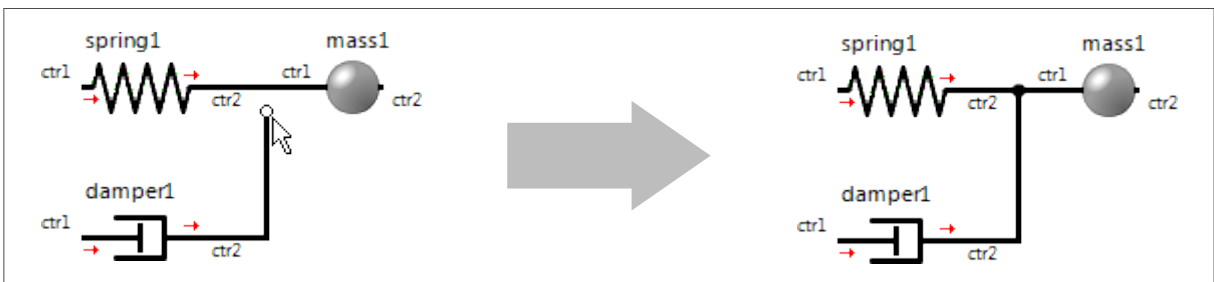



Fig. 9: Connecting a model element to another connection

With the created structure, it is already possible to simulate a simple one-mass-oscillator.

### 4 Entering Parameters

The diagram view only shows the interaction of the different model elements with each other. In order to determine the properties of each individual element, it is necessary to specify the parameters.

Double-click  on the element *mass1* in the diagram view to open the properties window of this element. Click on the tab *Parameters* and set the value for *Mass* to 5 kg and for *Initial Displacement* to 20 mm. As *m* is the default unit for *Initial Displacement*, choose the unit *mm* in the tab next to the value as shown in figure 10. (Note: If you change the unit from *m* to *mm*, SimulationX will adapt the value accordingly [20 m → 20000 mm]. By holding shift while changing the unit, you can change only the parameter's unit and not its value [20 m → 20 mm].) Now, you can close the properties window of *mass1*.

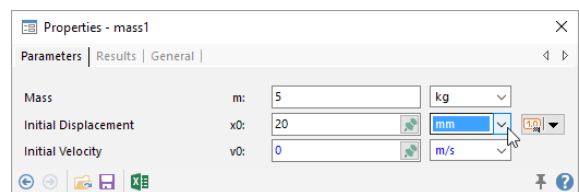

Fig. 10: Setting parameters of *mass1*

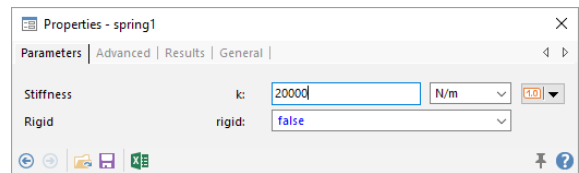

Fig. 11: Setting parameters of *spring1*

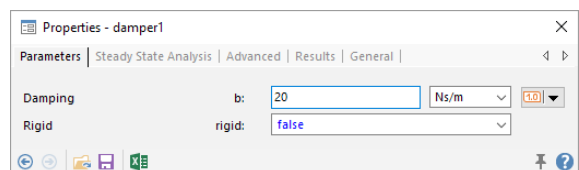

Fig. 12: Setting parameters of *damper1*

Set the properties for *spring1* and *damper1* in the same fashion as shown in figures 11 and 12.

## 5 Selecting results to be logged and displayed

Before starting a simulation, it is necessary to choose which specific results – out of all possible outputs – should be logged for later analyses.





Open the properties window of *mass1* again and go to the *Results* tab. Choose *Displacement* and *Velocity* as the results to be recorded by clicking  on the corresponding symbol . It will change to . Change the unit of Displacement to *mm* and close the properties window (see figure 13).



Fig. 13: Properties - mass1: Result logging

## 6 Starting the simulation

To control the simulation and specify its settings, open the *Properties dialog*  in the simulation control section (see figure 14) in the menu bar.

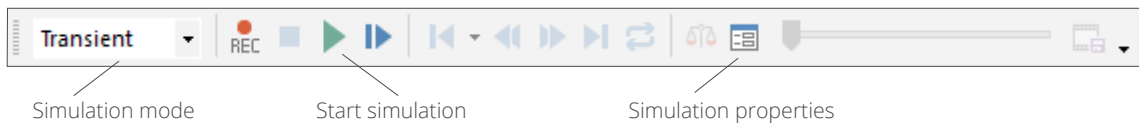

Fig. 14: Simulation control bar

Define the time period of the simulation by setting *Stop Time* to 2 s as shown in figure 15 (with the default *Start Time* at 0 s, the system will be simulated for two seconds).

Press  (*Start*) to start the simulation.

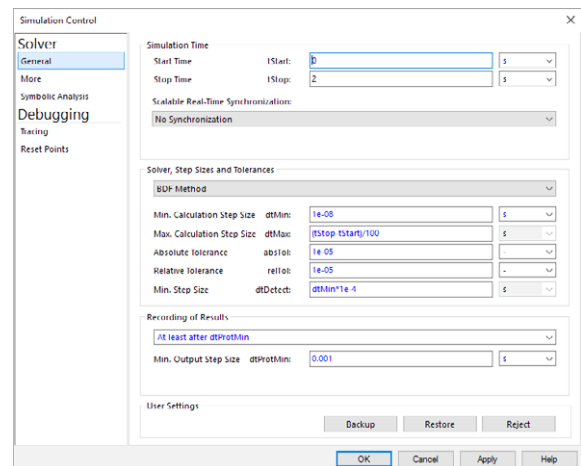



Fig. 15: Simulation control window

## 7 Working with graphical results

In order to display the recorded results as graphical representation, open the *Properties* window of *mass1* → *Results* (see figure 13), drag the symbol  for *Displacement* and drop it somewhere in the diagram view.

A result window as shown in figure 16 appears.

It shows the graphical analysis of the displacement of *mass1* over time.

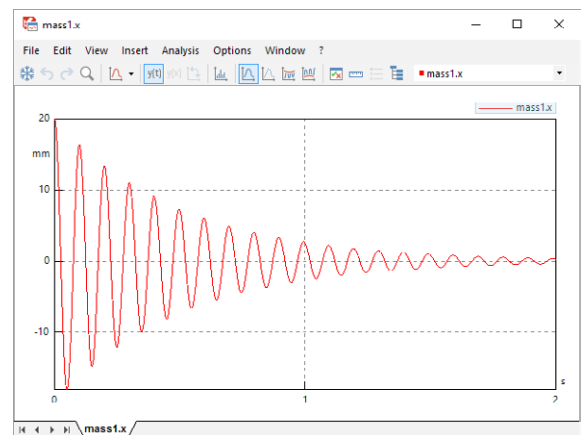

Fig. 16: Result window – Displacement of mass1

### III. Model extensions, further adjustments and post-processing

Applying the methods shown in chapter II, you will create a two-mass oscillator and learn about further adjustments and modification methods as well as post-processing.

#### 1 Create an alternative model structure

Place the element *Spring-Damper Backlash* and the element *Mass* from the library *Linear Mechanics* in the diagram view beside your model from chapter II and connect both new elements.

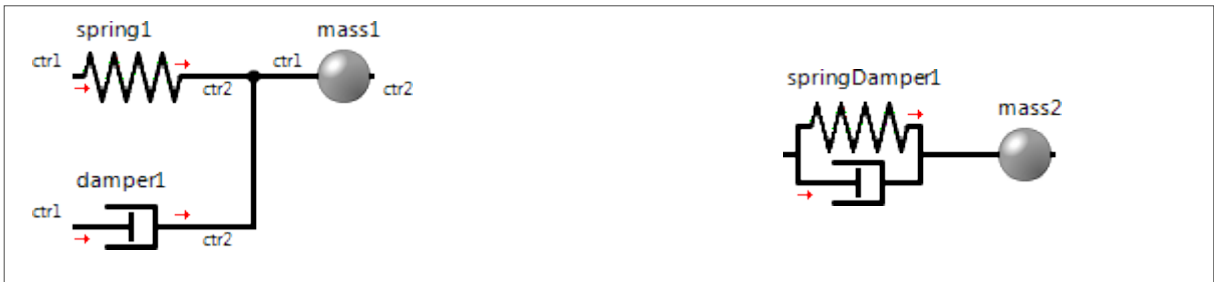

Fig. 17: Diagram view with two new elements

As you will see in the following steps, the element type *Spring-Damper Backlash* can represent the same physical correlation as the single elements *spring* and *damper* (depending on the parameters).

#### 2 Change parameters using the parameters table

Select springDamper1 in the diagram view. Its parameters are now displayed in the parameters table (see figure 18).

Parameters			
Comment	Name	Current Value	Unit
Properties	kind	Spring-Damper-...	
Stiffness of Contact	k	20000	N/m
Damping of Contact	b	20	Ns/m

Fig. 18: Setting parameters of *springDamper1* via the parameters table

Change their values by double-clicking in the box with the corresponding value and set the stiffness of *springDamper1* to 20000 N/m and damping to 20 Ns/m.

Table 2: Parameters of mass2

Change the properties of mass2 in the same manner with the values given in table 2.

model element	parameter	value
mass2	Mass (m)	5 kg
	Initial Displacement (x0)	0 mm



*SpringDamper1* has now the same properties as the connected elements *spring 1* and *damper 1*.

#### 3 Restart calculation and compare the two models

Select mass2 and click on the result window symbol for the displacement in the results table (figure 19), it will change to . Now drag and drop the result window symbol for the displacement onto the diagram view.

Results				
Comment	Name	Current Value	Unit	Protocol
Inertia Force	Fa	0	N	
Displacement	x	0	mm	
Velocity	v	0	m/s	
Acceleration	a	0	m/s <sup>2</sup>	
Change of Kinetic Energy	Pk	0	kW	

Fig. 19: Results table of mass2

As the new model has not yet been simulated, no simulation results are available in the result window. Reset the previous calculation by clicking  (Back to Start) in the menu bar. Restart the simulation with  (Start). You can now compare the displacements of mass1 and mass2. The results should be identical.

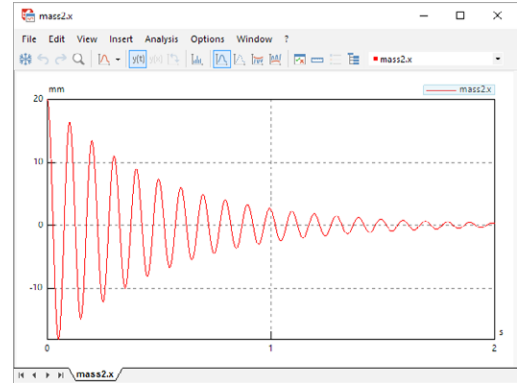
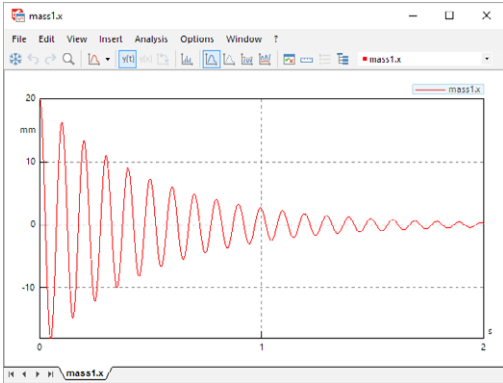



Fig. 20: Result window of mass1 and mass 2

#### 4 Copy and paste several elements and extend your model

Select springDamper1 and mass2 by drawing a rectangle in the diagram view holding . Releasing the mouse button selects all marked model elements.

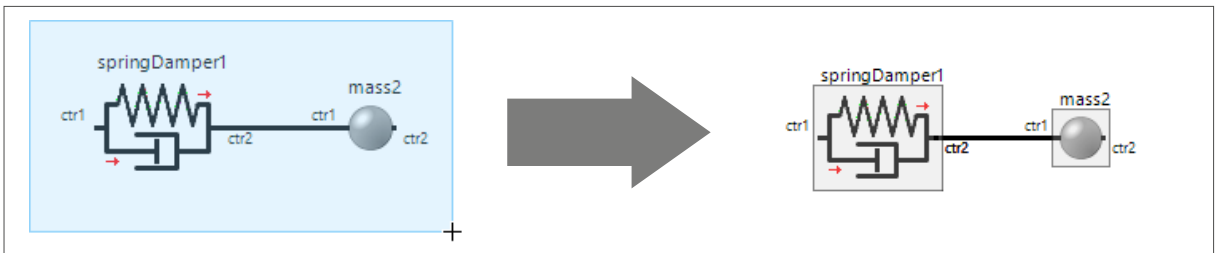



Fig. 21: Selecting the model structure in the diagram view

Copy the model structure of the one-mass oscillator by dragging one of the selected elements while pressing and holding **ctrl + ** and drop it in a position as shown in figure 22.

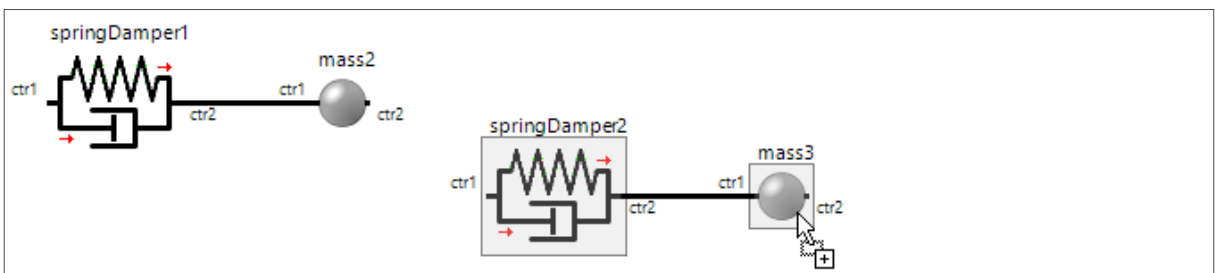

Fig. 22: Copying a model structure by drag and drop



As you can see in the corresponding properties windows, the copied model elements have the same settings (parameters, results, ...) as their corresponding archetypes. Link *springDamper2* and *mass2* and the structure will look like the one in figure 23.

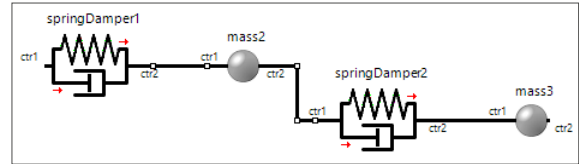

Fig. 23: Model structure of a two-mass oscillator

## 5 Customize the appearance of your network model

Activate the connection between *mass2* and *springDamper2* by clicking on the connection.

Change the routing of the connection between those two elements by grabbing a control point (see figure 24 – the cursor will change to ) and drag it to a different position.

In order to delete the connection between *mass2* and *SpringDamper2*, press *Shift* while hovering over the connector. As soon as the symbol appears next to the cursor (see figure 25), click and the connection with the next element will be deleted. (Please note: If a selected connection is deleted with *Del*, not only the connection between one element and the next one is deleted, but also all selected connection lines are deleted.)

(Alternatively: Press (*Undo*) in order to undo this change.)

In order to simply move a line parallelly, you can also grab the line (instead of a point) by hovering over the selected connection and as soon as the cursor changes to , you can move the line to a parallel position (see figure 26).

Please note: The cursor will only be available if there are two rectangular bends in this connection, before the next model element or node (see figure 27).

Table 3: Parameters of *springDamper2* and *mass3*

Model element	Parameter	Value
<i>springDamper2</i>	Stiffness (k)	1000 N/m
<i>springDamper2</i>	Damping (b)	2 Ns/m
<i>mass3</i>	Initial Displacement (x0)	0 mm
	Mass (m)	1 kg

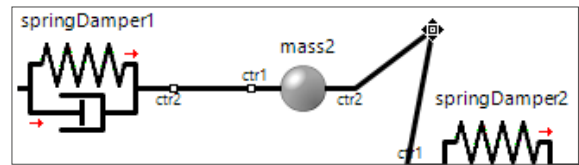

Fig. 24: Changing the position of a connection point

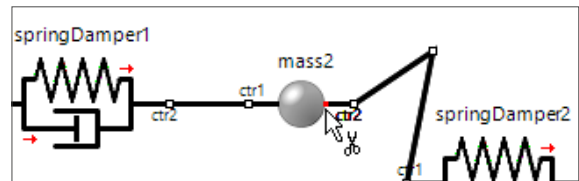

Fig. 25: Cutting a connection between two model elements

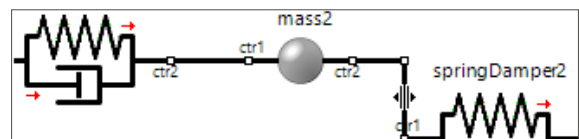

Fig. 26: Moving a connection parallelly

## 6 Parameterize the copied structure and set simulation parameters through the parameters table

Change the parameters of *springDamper2* and *mass3* in accordance with table 3.

Afterwards, change the parameters of the simulation by clicking on an empty space in the diagram view. The parameters for the simulation appear in the parameters table. Set the values as shown in figure 28.





Fig. 27: Precondition for parallel movement of a connection

Parameters			
Comment	Name	Current Value	Unit
Start Time	tStart	0	s
Stop Time	tStop	3	s

Fig. 28: Parameters table

## 7 Run your extended model

Reset the calculation, by clicking  (*Back to Start*) in the menu bar. Restart the simulation with  (*Start*). The result window *mass2.x* will change (see figure 29 [left]) due to the extension of the simulation time in the step before. Click on *mass3* and drag the result window symbol () for the displacement into the diagram view. The displacement of *mass3* is displayed in a separate window (see figure 29 on the right).

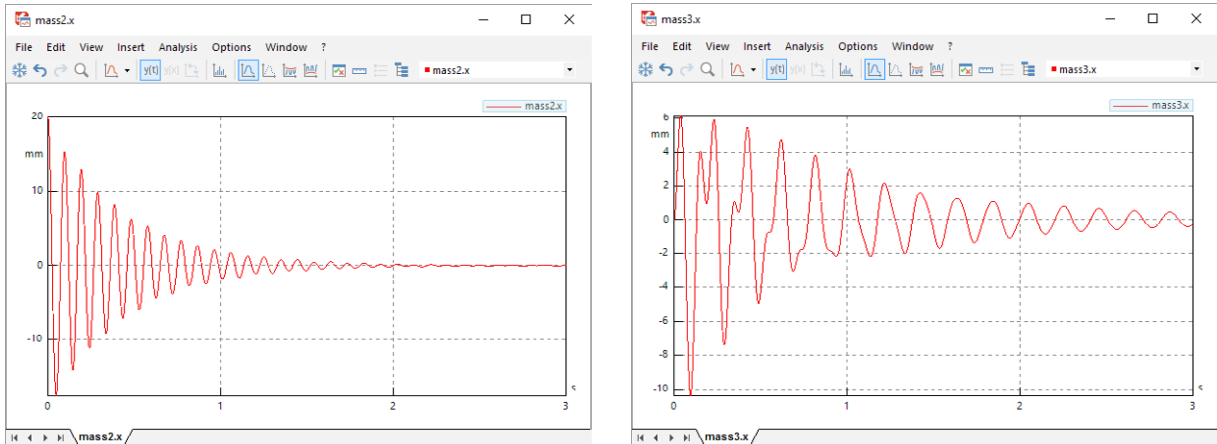

Fig. 29: Displacements of *mass2* and *mass3* in separate windows

## 8 Merge result windows

For better comparison of the interaction between both masses, you can display both curves within one diagram. In order to do this, grab the symbol of *mass2.x* in its result window and drop it near the center of the result window of *mass3.x* as shown in figure 30. (Be careful not to drop *mass2.x* on one of the operator buttons in the middle of the window as this will result in both functions to be merged.) Both curves are now displayed within one diagram. As the graphs have the same units, both share the same x and y axes.

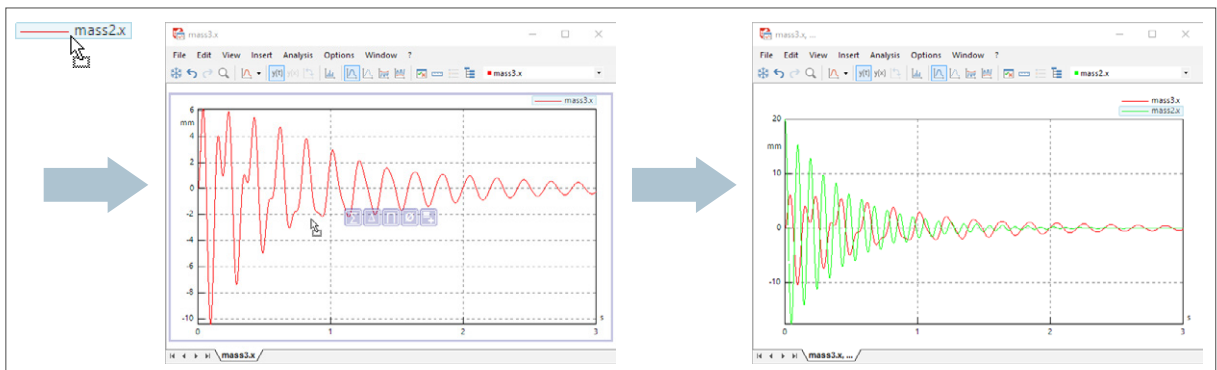



Fig. 30: Merging two result windows

To change the settings of the result window, press  (*Property Bar*) in its menu bar. By selecting *Panel*, you can specify settings like font, font size, line width etc. of the diagram. To improve the contrast between both graphs, select *mass2.x* and change the color to dark blue (see figure 31).

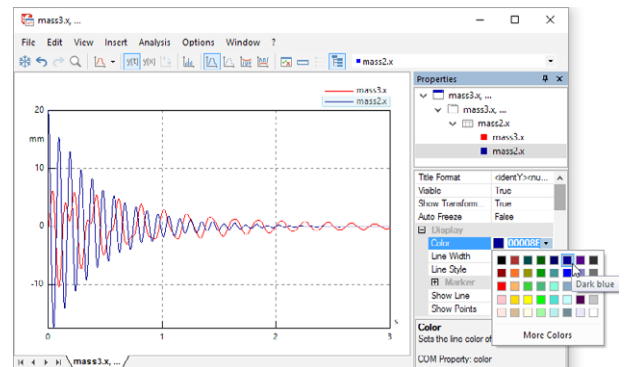



Fig. 31: Customization of result windows settings

## 9 Perform a Fast Fourier Transformation (FFT)

As you could see in figure 29, the vibrational behavior of *mass3* was influenced by eigenfrequencies. In order to analyze the vibrational behavior of both masses in the frequency domain, there is an option to perform a Fast Fourier Transformation (FFT) in the result window.

Click  (*Fast Fourier Transformation (FFT)*) in the menu bar of the result window. The appearance of the result window changes as displayed in figure 32.

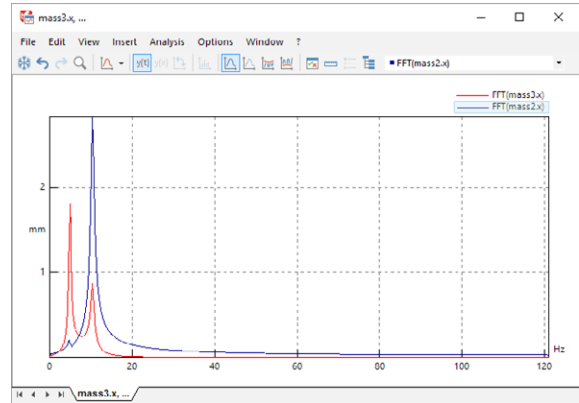
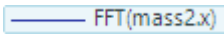



Fig. 32: Fast Fourier Transformation

## 10 Take measurements of the graph

Select  to activate the frequency spectrum of *mass2*. Click  in the result window, hold the mouse button and drag it towards the blue graph. You will see a crosshair and the exact values for x and y at the chosen point (see figure 33). As long as you keep the mouse button pushed, the crosshair is attached to the graph and will follow its course, while the corresponding values are displayed in the box.

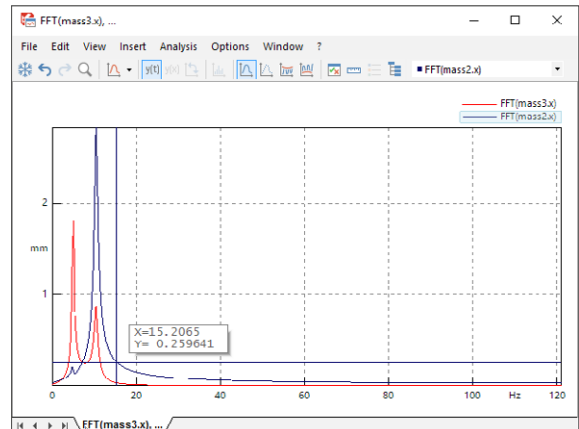



Fig. 33: Measurement of explicit values from the graph

## 11 Compare different parameter settings

Click  on  (*Freeze*) in the result window to pin an image of the diagram to the background of the window. Change the *stiffness k* of *springDamper1* to 40000 N/m. Reset the calculation to the start and restart it. You will now see the results of the calculation with changed parameters in the foreground and the ones from the previous calculation slightly faded to the background (see figure 34).

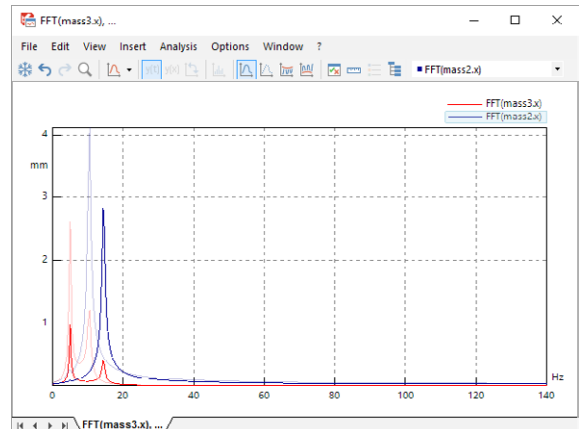



Fig. 34: Two eigenfrequencies with values of a previous calculation in the background

## Conclusion

In this tutorial, you have learned the basic concepts of building a model. The model's system behavior was simulated and analyzed. The presented example was taken from the mechanics domain, but the general approach to creating and analyzing system models is the same for all other physical domains in SimulationX. Depending on the user's preferences and the specific requirements for each task, there are often several ways to solve it. This introductory tutorial gave you a small insight into SimulationX' various features.

If you want to learn more about how to use SimulationX, please take a look at

- SimulationX Help: *Help* → *SimulationX Help*; alternatively click on  (*Help*) or press *F1*
- SimulationX User Manual and Library Manual (*Help* → *Documents* → *User Manual/Library Manual*)
- Further SimulationX tutorials (*Help* → *Documents* → *Documents Online* )
- *SimulationX* training courses: <http://www.simulationx.com/academy>
- Contact our global sales teams: [www.simulationx.com/global](http://www.simulationx.com/global)