



(51) International Patent Classification:

*F16H 1/02* (2006.01) *F16H 57/02* (2012.01)  
*F16H 1/20* (2006.01)

(21) International Application Number:

PCT/CA20 15/050861

(22) International Filing Date:

8 September 2015 (08.09.2015)

(25) Filing Language:

English

(26) Publication Language:

English

(30) Priority Data:

62/048,776 10 September 2014 (10.09.2014) US

(72) Inventor; and

(71) Applicant : **STOCCO, Leo** [CA/CA]; 3250 W. 29th Ave., Vancouver, British Columbia V6L 1Y6 (CA).

(81) Designated States (unless otherwise indicated, for every kind of national protection available): AE, AG, AL, AM, AO, AT, AU, AZ, BA, BB, BG, BH, BN, BR, BW, BY, BZ, CA, CH, CL, CN, CO, CR, CU, CZ, DE, DK, DM, DO, DZ, EC, EE, EG, ES, FI, GB, GD, GE, GH, GM, GT, HN, HR, HU, ID, IL, IN, IR, IS, JP, KE, KG, KN, KP, KR, KZ, LA, LC, LK, LR, LS, LU, LY, MA, MD, ME, MG,

MK, MN, MW, MX, MY, MZ, NA, NG, NI, NO, NZ, OM, PA, PE, PG, PH, PL, PT, QA, RO, RS, RU, RW, SA, SC, SD, SE, SG, SK, SL, SM, ST, SV, SY, TH, TJ, TM, TN, TR, TT, TZ, UA, UG, US, UZ, VC, VN, ZA, ZM, ZW.

(84) Designated States (unless otherwise indicated, for every kind of regional protection available): ARIPO (BW, GH, GM, KE, LR, LS, MW, MZ, NA, RW, SD, SL, ST, SZ, TZ, UG, ZM, ZW), Eurasian (AM, AZ, BY, KG, KZ, RU, TJ, TM), European (AL, AT, BE, BG, CH, CY, CZ, DE, DK, EE, ES, FI, FR, GB, GR, HR, HU, IE, IS, IT, LT, LU, LV, MC, MK, MT, NL, NO, PL, PT, RO, RS, SE, SI, SK, SM, TR), OAPI (BF, BJ, CF, CG, CI, CM, GA, GN, GQ, GW, KM, ML, MR, NE, SN, TD, TG).

Declarations under Rule 4.17:

- as to the identity of the inventor (Rule 4.1 7(i))
- as to applicant's entitlement to apply for and be granted a patent (Rule 4.1 7(H))
- as to the applicant's entitlement to claim the priority of the earlier application (Rule 4.1 7(in))

Published:

- with international search report (Art. 21(3))

WO 2016/037271 A1

(54) Title: HYBRID ORBITLESS GEARBOX

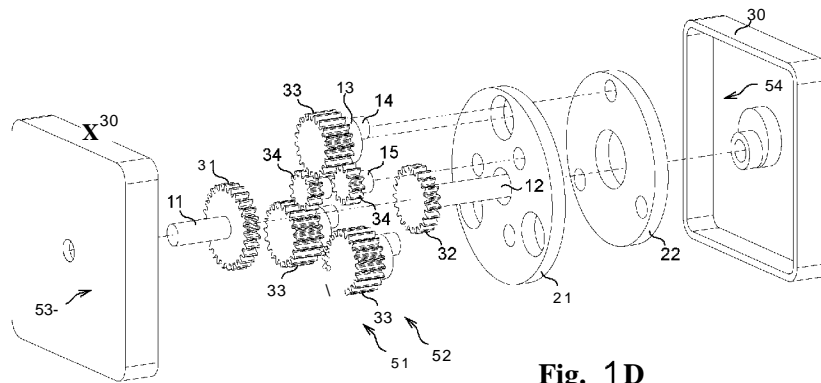

Fig. 1D

(57) Abstract: A Hybrid Orbitless gearbox combines the high speed capabilities of an Orbitless first stage with the high ratio of a Coupled Orbitless second stage. The two stages share a common set of carriers and offset members for high compactness and simplicity. A Coupled Orbitless second stage may also function on its own. Its all-pinion design supports a variety of engaging members that include gears, chains, sprockets, belts, cables and pulleys, among others. Stepped engaging members further amplify the reduction ratio and variable pitch diameter engaging members provide an infinitely variable transmission ratio.

## HYBRID ORBITLESS GEARBOX

### REFERENCE TO EARLIER FILED APPLICATIONS

- [01] This application claims priority to U.S. Provisional Application No. US 62/048,776 filed September 10, 2014. This patent application is incorporated herein entirely by reference. This application improves upon International Application No. PCT/CA20 15/050423 filed May 11, 2015 which discloses an Orbitless gearbox.

### TECHNICAL FIELD

- [02] The disclosure herein relates to a gearbox comprising a plurality of gears or other engaging members. More particularly, it relates to an apparatus providing a drive member that rotates at a different rate as a driven member.

### BACKGROUND

- [03] An Orbitless gearbox comprises a central gear and a number of offset crankshaft pinions, carried by a pair of offset carriers. It has lower pitch velocity, bearing speed, and windage than a Planetary gearbox but produces a lower speed ratio. It is, therefore, more energy efficient, but requires a greater volume for a given speed ratio.
- [04] A Coupled Orbitless gearbox comprises coupling members which engage the central and offset members whereby they rotate in a common direction. This amplifies and inverts the speed ratio so that the roles of the input and output members are interchanged.
- [05] Since the carriers are the output of an Orbitless reduction gearbox and the input of a Coupled Orbitless reduction gearbox, integrating an Orbitless first stage with a Coupled Orbitless second stage, allows a common set of carriers and offset members to be shared by both stages. A Hybrid Orbitless gearbox combines the superior efficiency and high-speed characteristics of an Orbitless gearbox with the high reduction ratio of a Coupled Orbitless gearbox.

## SUMMARY

- [06] Certain exemplary embodiments comprise a reference member, a first and second carrier, a second central member, one or more offset members, one or more coupling members, and a number of coupling axes equal to the number of coupling members. The second central member and all offset and coupling members are engaging members. The reference member comprises a central axis and a first and second carrier axis. Each carrier comprises a rotation axis and a number of offset axes equal to the number of offset members. Each offset member comprises a first and second member axis. All axes are parallel. The first and second carrier axes and all associated first and second member axes are spaced apart by the carrier distance. Each offset axis and the associated rotation axis are spaced apart by an offset distance. All offset axes are arranged circumferentially around the associated rotation axis. The second central member and the central axis, the first rotation axis and the first carrier axis, the second rotation axis and the second carrier axis, each first member axis and a different first offset axis, each second member axis and a different second offset axis, and each coupling member and a different coupling axis, are co-axial and rotatably coupled. The coupling axes are arranged whereby the coupling members simultaneously engage the second central member and all offset members.
- [07] Certain exemplary embodiments further comprise a first central member which is an engaging member which is co-axial and rotatably coupled with the central axis.
- [08] In certain exemplary embodiments, the first central member simultaneously engages all offset members.
- [09] In certain exemplary embodiments, the first central member simultaneously engages all coupling members.
- [10] In certain exemplary embodiments, each offset member is a stepped engaging member.

- [11] In certain exemplary embodiments, each coupling member is a stepped engaging member.
- [12] In certain exemplary embodiments, one of the first or second carriers and all coupling axes are integral. The associated carrier axis and the central axis are co-axial.
- [13] Certain exemplary embodiments further comprise a third carrier comprising a third rotation axis. The third carrier and all coupling axes are integral. The third rotation axis and the central axis are co-axial and rotatably coupled.
- [14] Certain exemplary embodiments further comprise a variable speed ratio between the second central member and the offset members.
- [15] Certain exemplary embodiments comprise a reference member, a first and second carrier, a first and second central member, one or more offset members, and one or more coupling members. The first and second central member and all offset and coupling members are engaging members. The reference member comprises a central axis and a first and second carrier axis. Each carrier comprises a rotation axis and a number of offset axes equal to the number of offset members. Each offset member comprises a first and second member axis. All axes are parallel. The first and second carrier axes and all associated first and second member axes are spaced apart by the carrier distance. Each offset axis and the associated rotation axis are spaced apart by an offset distance. All offset axes are arranged circumferentially around the associated rotation axis. The first central member and the central axis, the second central member and the central axis, the first rotation axis and the first carrier axis, the second rotation axis and the second carrier axis, each first member axis and a different first offset axis, and each second member axis and a different second offset axis, are co-axial and rotatably coupled. The first central

member simultaneously engages all offset members. The coupling members simultaneously engage the second central member and all offset members.

- [16] In certain exemplary embodiments, each coupling member is a stepped engaging member.
- [17] Certain exemplary embodiments further comprise a variable speed ratio between the second central member and the offset members.
- [18] In certain exemplary embodiments, a reference member, a first and second carrier, a first and second central member, one or more offset members, and one or more coupling members are provided. The first and second central members and all offset and coupling members are provided with an engaging means. The reference member is provided with a central axis and a first and second carrier axis. Each carrier is provided with a rotation axis and a number of offset axes equal to the number of offset members. Each offset member is provided with a first and second member axis. All axes are located whereby they are all parallel. The first and second carrier axes and all associated first and second member axes are spaced apart by the carrier distance. Each offset axis and the associated rotation axis are spaced apart by an offset distance. All offset axes are arranged circumferentially around the associated rotation axis. The first central member and the central axis, the second central member and the central axis, the first rotation axis and first carrier axis, the second rotation axis and second carrier axis, each first member axis and a different first offset axis, and each second member axis and a different second offset axis, are co-axially located and rotatably coupled. The coupling members are simultaneously engaged with the second central member and all offset members.
- [19] In certain exemplary embodiments, the first central member is simultaneously engaged

with all offset members.

- [20] In certain exemplary embodiments, the first central member is simultaneously engaged with all coupling members.
- [21] In certain exemplary embodiments, each offset member is provided with a first engaging step and a second engaging step.
- [22] In certain exemplary embodiments, each coupling member is provided with a first engaging step and a second engaging step.
- [23] In certain exemplary embodiments, one of the first or second carriers is provided with a number of coupling axes equal to the number of coupling members. Each coupling member and a different coupling axis are co-axially located and rotatably coupled. The associated carrier axis and the central axis are co-axially located.
- [24] In certain exemplary embodiments, a third carrier is provided which is provided with a third rotation axis and a number of coupling axes equal to the number of coupling members. Each coupling member and a different coupling axis, and the third rotation axis and the central axis, are co-axially located and rotatably coupled.
- [25] In certain exemplary embodiments, a variable speed ratio is provided between the second central member and the offset members.

#### **BRIEF DESCRIPTION OF DRAWINGS**

- [26] Figs 1A-1D are respectively, a schematic side view, two partial front views, and an exploded perspective view, in accordance with a first exemplary embodiment depicting the present invention comprising gear engaging members.
- [27] Figs IE- IF are respectively a rear view of an offset member, and a perspective view of an engaged offset and coupling member, in accordance with the first exemplary embodiment of the present invention.

- [28] Fig 2 is a partial front view in accordance with a second exemplary embodiment depicting the present invention comprising two coupling members engaging each offset member.
- [29] Figs 3A-3B are respectively, a schematic side view and an exploded perspective view, in accordance with a third exemplary embodiment depicting the present invention comprising stepped coupling members.
- [30] Fig 4 is a schematic side view in accordance with a fourth exemplary embodiment depicting the present invention comprising a ring first central member engaging stepped coupling members.
- [31] Fig 5 is a schematic side view in accordance with a fifth exemplary embodiment depicting the present invention comprising three non-co-axial carriers.
- [32] Fig 6 is a schematic side view in accordance with a sixth exemplary embodiment depicting the present invention comprising stepped offset members.
- [33] Figs 7A-7B are respectively, an exploded perspective view and a partial front view, in accordance with a seventh exemplary embodiment depicting the present invention comprising flexible coupling members.
- [34] Fig 7C is a perspective view of a stepped second central member, in accordance with the seventh exemplary embodiment of the present invention.
- [35] Fig 8 is a partial front view in accordance with an eighth exemplary embodiment depicting the present invention comprising two serpentine coupling members, each engaging a pair of adjacent offset members.
- [36] Fig 9 is a partial front view in accordance with a ninth exemplary embodiment depicting the present invention comprising one flexible coupling member and one serpentine

coupling member.

- [37] Figs 10A-10B are respectively, a schematic side view and an exploded perspective view in accordance with a tenth exemplary embodiment depicting the present invention comprising an integral first drive-shaft and first carrier.
- [38] Fig 11 is a schematic side view in accordance with an eleventh exemplary embodiment depicting the present invention comprising an integral first drive-shaft and second carrier, providing offset first and second drive-shafts.
- [39] Fig 12 is a schematic side view in accordance with a twelfth exemplary embodiment depicting the present invention comprising multiple second drive-shafts, each providing a different speed ratio.

#### REFERENCE NUMERALS

0 - central axis	21 - first carrier
1 - first carrier axis	22 - second carrier
2 - second carrier axis	23 - third carrier
3 - first rotation axis	30 - reference member
4 - second rotation axis	31 - first central member
5 - third rotation axis	32 - second central member
6 - first offset axis	33 - offset member
7 - second offset axis	34 -coupling member
<b>8</b> - first member axis	40 - carrier distance
9 - second member axis	41 - offset distance
10 - coupling axis	42 - coupling distance
11 - first drive-shaft	51 - first stage



12 - second drive-shaft	52 - second stage
13 - first shaft	53 - front
14 - second shaft	54 - rear
15 - coupling shaft	

## DEFINITIONS

- [40] A gear, sprocket, chain, pulley, belt, cable, friction or magnetic coupling, or any other member that engages and transmits energy to a mate is defined as an engaging member.
- [41] An engaging member that engages and transmits energy between two or more engaging members is defined as a coupling member.
- [42] A chain, belt, cable, or any other coupling member that changes shape while transmitting energy is defined as a flexible coupling member.
- [43] A flexible coupling member that simultaneously couples three or more engaging members is defined as a serpentine coupling member.
- [44] A flexible coupling comprising two counter-acting, pre-loaded cables that are fixedly attached to two pulleys is defined as a capstan cable coupling.
- [45] An engaging member that engages on its exterior surface is defined as a pinion.
- [46] An engaging member that engages on its interior surface is defined as a ring.
- [47] A member that is coupled to an axis by three or more encircling engaging members but by no other mechanical means is defined as floating.
- [48] Two parallel, offset shafts integrated into a common member is defined as a crankshaft.
- [49] An apparatus that scales the relative speed and torque of a drive and driven member is defined as a gearbox, whether or not it comprises any gears.
- [50] A gearbox that reduces velocity and amplifies torque is defined as a reduction gearbox.
- [51] A gearbox that amplifies velocity and reduces torque is defined as an overdrive gearbox.

- [52] A gearbox that may function as either a reduction or an overdrive gearbox is defined as back-drivable.
- [53] A gearbox comprising a reference member, two offset carriers, a central member and one or more crankshaft offset members is defined as an Orbitless gearbox.
- [54] An Orbitless gearbox further comprising one or more coupling members is defined as a Coupled Orbitless gearbox.
- [55] A gearbox which integrates two or more Orbitless and/or Coupled Orbitless gearboxes with a common set of carriers is defined as a Hybrid Orbitless gearbox.

## **DESCRIPTION OF EMBODIMENTS**

- [56] Wherever possible, the same reference numerals are used throughout the accompanying drawings and descriptions to refer to the same or similar parts. Components such as bearings, retainers and fasteners that do not substantially contribute to the understanding of the invention are neglected for the sake of simplicity.
- [57] Although spur gears, pulleys, belts and cables are depicted in the accompanying drawings, it is understood that many other engaging means would suffice, such as conical, radial, offset, spiral, helical, double helical, herring-bone, or roller tooth gears, friction or magnetic couplings, and chain drives. It is also understood that associated gears may comprise any face width, tooth profile, pressure angle, or module and may be made from metal, plastic, or any other appropriate material.
- [58] Although a male shaft and female race are used to depict a rotatable coupling in the accompanying drawings, it is understood that any other means will suffice, such as anti-friction bearings, bushings, or low friction coatings, materials, surface treatments or lubricants. It is also understood that the male and female members of a rotatable coupling may often be interchanged.

- [59] Although a shaft is used to depict a drive or driven member in the accompanying drawings, it is understood that any other means will suffice, such as an engaging member, a keyed, splined, or threaded hole, or a magnetic or electrostatic coupling.
- [60] Although three or four offset members **33** are depicted in certain accompanying drawings, it is understood that any number of offset members **33** may be included, as long as they do not mechanically interfere.
- [61] Although two stages are depicted sharing a common set of carriers in certain accompanying drawings, it is understood that any number of stages may be included, as long as they do not mechanically interfere.
- [62] It is understood that multiple gearboxes may be joined in series or in parallel or combined with any other type of gearbox to provide a desired speed ratio or other characteristic.
- [63] It is understood that a back-drivable gearbox may provide either a reduction or an overdrive ratio by interchanging the roles of its drive and driven members. In fact, the roles of the reference member, drive member and driven member may all be interchanged to obtain a desired speed ratio, or to cause the drive and driven members to rotate in the same or opposite directions. Similarly, if any one is used as a drive member and the remaining two are used as driven members, a differential mechanism is obtained. Reduction, overdrive, differential, and reverse gearboxes are all contemplated.
- [64] It is understood that any one of the reference member **30**, the first central member **31**, the second central member **32**, an offset member **33**, a coupling member **34**, or the first, second, or third carrier **21**, **22**, **23**, may act as the reference with any other member acting as the drive or driven member.
- [65] Although certain exemplary embodiments depict the first drive-shaft **11** and the first or

- second carrier **21, 22** as integral, all carriers **21, 22, 23** rotate in unison so the first drive-shaft **11** could be integral with any of the first, second or third carriers **21, 22, 23**.
- [66] It is understood that the individual offset members **33** may have non-uniform first and second member axes **8, 9** as long as the associated first and second offset axes **6, 7** are similarly non-uniform, although additional vibration may result.
- [67] Although certain exemplary embodiments depict all offset axes **6, 7** as being circumferentially equally spaced around the associated rotation axis **3, 4**, it is understood that they may be unequally spaced, although additional vibration may result.
- [68] Although certain exemplary embodiments depict a first, second or third carrier **21, 22, 23**, that is rotatably coupled about its center, it is understood that rotational coupling could be provided between the interior of the case **30** and the exterior of the associated carrier **21, 22, 23**. Alternatively, a first, second or third carrier **21, 22, 23**, that is rotatably coupled to the central axis **0**, may be a floating carrier which is not explicitly coupled to the case **30**. Similarly, the first or second central member **31, 32**, may be floating members.
- [69] A representative sample of embodiments is included in the accompanying drawings for exemplary purposes only. A great number of kinematic arrangements, types of engaging members, and combinations of disclosed features are also contemplated. The scope of the present invention is not limited to the embodiments included but spans all possible combinations anticipated by the specification and claims.
- [70] Figs 1A-1F illustrate a first exemplary embodiment of the present invention providing a reduction ratio between a first drive-shaft **11** and a second drive-shaft **12**.
- [71] The first exemplary embodiment comprises a reference member **30**, a first carrier **21**, a second carrier **22**, a first central member **31**, a second central member **32**, three offset

- members **33**, and three coupling members **34**.
- [72] The reference member **30** acts as the case of the gearbox and comprises a central axis **0**, a first carrier axis **1**, and a second carrier axis **2**, all of which are parallel. The first carrier axis **1** and the central axis **0** are co-axial. The second carrier axis **2** and the central axis **0** are spaced apart by a carrier distance **40**.
- [73] The first carrier **21** comprises a first rotation axis **3**, three first offset axes **6**, and three coupling axes **10**. All first offset axes **6** are circumferentially equally spaced. Each first offset axis **6** and the first rotation axis **3** are spaced apart by an offset distance **41**. All coupling axes **10** are circumferentially equally spaced. Each coupling axis **10** and the first rotation axis **3** are spaced apart by a coupling distance **42**.
- [74] The second carrier **22** comprises a second rotation axis **4** and three second offset axes **7**. All second offset axes **7** are circumferentially equally spaced. Each second offset axis **7** and the second rotation axis **4** are spaced apart by the offset distance **41**.
- [75] The first rotation axis **3** and the first carrier axis **1** are co-axial and rotatably coupled. The second rotation axis **4** and the second carrier axis **2** are co-axial and rotatably coupled.
- [76] Each offset member **33** comprises a co-axial first shaft **13** defining a first member axis **8**, and an offset second shaft **14** defining a second member axis **9**, which are parallel, spaced apart by the carrier distance **40**, and together define a crankshaft. Each coupling member **34** comprises a co-axial coupling shaft **15**.
- [77] Each first member axis **8** and a different first offset axis **6** are co-axial and rotatably coupled. Each second member axis **9** and a different second offset axis **7** are co-axial and rotatably coupled. Each coupling shaft **15** and a different coupling axis **10** are co-axial and rotatably coupled.

- [78] The first central member **31** and first drive-shaft **11** are co-axial and integral. The second central member **32** and second drive-shaft **12** are co-axial and integral. The first central member **31** and the central axis **0** are co-axial and rotatably coupled. The second central member **32** and the central axis **0** are co-axial and rotatably coupled.
- [79] The first central member **31**, second central member **32**, all offset members **33**, and all coupling members **34** are pinion gears. The first central member **31** simultaneously engages all offset members **33**. Each coupling member **34** simultaneously engages the second central member **32** and a different offset member **33**. Together, the coupling members **34** co-operate to simultaneously engage the second central member **32** and all offset members **33**.
- [80] The first central member **31**, all offset members **33**, and the carriers **21**, **22**, together define a first stage **51** which is an Orbitless gearbox. The second central member **32**, all offset members **33**, all coupling members **34**, and the carriers **21**, **22**, together define a second stage **52** which is a Coupled Orbitless gearbox. The offset members **33** and carriers **21**, **22** are shared by the first and second stages **51**, **52**, which together define a Hybrid Orbitless gearbox.
- [81] Fig IE illustrates non-uniform placement of the second shafts **14a-14c** on the associated offset members **33a-33c** that is required for the first exemplary embodiment to be assemble-able. The requirement for non-uniform second shaft **14** placement depends on the particular pitch diameters and spacing of the associated engaging members.
- [82] Fig IF illustrates a detail view of an offset member **33** and an engaged coupling member **34**. The offset member **33** has a large face width, a portion of which is engaged by the first stage **51**, and a portion of which is engaged by the second stage **52**.

- [83] Fig 2 illustrates a second exemplary embodiment of the present invention which is similar to the first exemplary embodiment except two redundant coupling members **34a**, **34b** simultaneously engage the second central member **32** and each offset member **33**. Both coupling members **34a**, **34b** are depicted with uniform pitch diameters. If the coupling members **34a**, **34b** are non-uniform, non-uniform coupling distances **42** are required for the associated coupling members **34a**, **34b**.
- [84] Figs 3A-3B illustrate a third exemplary embodiment of the present invention which is similar to the first exemplary embodiment except each coupling member **34** is a stepped coupling member comprising a first step **34a**, and a second step **34b**. An offset member **33** engages each first step **34a** and the second central member **32** simultaneously engages all second steps **34b**. In addition, the second carrier **22** is located in front of the offset members **33** and the second central member **32** is located behind the first carrier **21**, which is a floating carrier.
- [85] Fig 4 illustrates a fourth exemplary embodiment of the present invention which is similar to the first exemplary embodiment except each coupling member **34** is a stepped coupling member comprising a first step **34a** and a second step **34b**. The first central member **31** is a ring which simultaneously engages all first steps **34a** and each second step **34b** simultaneously engages the second central member **32** and an offset member **33**.
- [86] Fig 5 illustrates a fifth exemplary embodiment of the present invention which is similar to the first exemplary embodiment except it further comprises a third carrier **23** which is integral with all coupling axes **10** and comprises a third rotation axis **5**. The third rotation axis **5** and the central axis **0** are co-axial and rotatably coupled, the second carrier **22** is located in front of the offset members **33**, each first shaft **13** and the associated offset

member **33** are non-co-axial, and the first carrier axis **1** and the central axis **0** are non-co-axial.

- [87] Fig 6 illustrates a sixth exemplary embodiment of the present invention which is similar to the first exemplary embodiment except each offset member **33** is a stepped offset member comprising a first step **33a**, and a second step **33b**. All first steps **33a** simultaneously engage the first central member **31** and each second step **33b** engages a coupling member **34**.
- [88] Figs 7A-7C illustrate a seventh exemplary embodiment of the present invention which is similar to the sixth exemplary embodiment except all offset members **33** are stepped offset members **33** comprising a gear first step **33a** and a pulley second step **33b**, all coupling members **34** are flexible coupling members **34**, there are no coupling axes **10**, and the second central member **32** is a stepped pulley.
- [89] Fig 7B depicts the second stage **52** of the seventh exemplary embodiment.
- [90] Fig 7C illustrates a detail view of the second central member **32** comprising three steps **32a-32c** which each engage a different flexible coupling member **34**. All steps **32a-32c** have a common pitch diameter and are included to avoid mechanical interference.
- [91] Fig 8 illustrates an eighth exemplary embodiment of the present invention which is an alternative configuration of the second stage **52** of the seventh exemplary embodiment. It comprises four offset members **33b** and two serpentine coupling members **34**, each simultaneously engaging the second central member **32** and two offset members **33**.
- [92] Fig 9 illustrates a ninth exemplary embodiment of the present invention which is an alternative configuration of the second stage **52** of the seventh exemplary embodiment. It comprises three offset members **33b**, one of which further comprises a third step **33c**. A



serpentine engaging member **34a** simultaneously engages all offset member second steps **33b**. A flexible engaging member **34b** simultaneously engages the second central member **32** and the offset member third step **33c**. Providing the second central member **32** and the offset member third step **33c** with a variable pitch diameter results in an infinitely variable speed ratio.

[93] Figs 10A-10B illustrate a tenth exemplary embodiment of the present invention which is similar to the first exemplary embodiment except the first central member **31** is absent, the first and second carriers **21, 22** are located in front of the offset members **33**, and the first drive-shaft **11** and the first carrier **21** are co-axial and integral. The absence of the first central member **31** eliminates the first stage **51** altogether, and leaves only the second stage **52**, which is a Coupled Orbitless gearbox.

[94] Fig 11 illustrates an eleventh exemplary embodiment of the present invention which is similar to the tenth exemplary embodiment except the first drive-shaft **11** and second carrier **22** are co-axial and integral. This embodiment provides offset first and second drive-shafts **11, 12**.

[95] Fig 12 illustrates a twelfth exemplary embodiment of the present invention which is similar to the first exemplary embodiment except the first central member **31** is a ring, the first central member **31** and an additional second drive-shaft **12a** are co-axial and integral, the first and second carriers **21, 22** are located in front of the offset members **33**, and the first drive-shaft **11** and the first carrier **21** are co-axial and integral. The first and second stages **51, 52**, each depict a Coupled Orbitless gearbox which both reside in a common plane and each comprise a second drive-shaft **12a, 12b** which each deliver a different speed ratio, and together depict a 2-speed Coupled Orbitless gearbox.

**EXAMPLES**

[96] As illustrated by the arrows in Fig IB, the first through ninth exemplary embodiments each comprise a first stage **51** comprising a first central member **31** and offset members **33** which are engaged whereby they counter-rotate with respect to the first carrier **21**. Each of these exemplary embodiments depict an Orbitless first stage **51**.

[97] As illustrated by the arrows in Figs 1C, 2, 7B, 8 and 9, the first through twelfth exemplary embodiments each comprise a second stage **52** comprising a second central member **32** and offset members **33** which are engaged whereby they rotate in a common direction with respect to the first carrier **21**. Each of these exemplary embodiments depict a Coupled Orbitless second stage **52**.

[98] In each of the examples herein, two gearbox speed ratios, **R** and **R'** are defined where **T<sub>1</sub>** is the number of turns of the first drive-shaft **11** and **T<sub>2</sub>** is the corresponding number of turns of the second drive-shaft **12**, all with respect to the reference member **30**.

$$R = \frac{T_1}{T_2} : 1 \quad R' = \frac{1}{R} : 1 = \frac{T_2}{T_1} : 1$$

[99] For each of the first and second stages **51**, **52**, two corresponding speed ratios, **R<sub>1</sub>**, **R<sub>1</sub>'**, **R<sub>2</sub>**, and **R<sub>2</sub>'**, are defined where **T<sub>c</sub>** is the number of turns of the carriers **21**, **22**, **23**, which all rotate in unison with respect to the reference member **30**.

$$R_1 = \frac{T_1}{T_c} : 1 \quad R_1' = \frac{T_c}{T_1} : 1 \quad R_2 = \frac{T_2}{T_c} : 1 \quad R_2' = \frac{T_c}{T_2} : 1$$

[100] A Hybrid Orbitless gearbox comprising an Orbitless first stage **51** and a Coupled Orbitless second stage **52** provides the following reduction ratio:

$$R = \frac{T_1}{T_2} : 1 = \frac{T_1}{T_c} \frac{T_c}{T_2} : 1 = R_1 R_2' : 1$$

[101] Speed ratios are computed from  $P_1$ ,  $P_2$ ,  $P_0$ ,  $P_a$ , and  $P_b$  which are the pitch diameters of the first central member **31**, second central member **32**, offset members **33**, coupling member first steps **34a**, and coupling member second steps **34b**, respectively. Only stepped coupling members **34** alter the speed ratio. When an engaging member is a gear with a module of 1, the pitch diameter is equal to the number of teeth.

[102] In each first stage **51**, the first central member **31** and all offset members **33** are engaged whereby they counter-rotate and provide the following speed ratios:

$$R_1 = 1 + \frac{P_o}{P_1} : 1 \quad R'_1 = \frac{P_1}{P_1 + P_o} : 1$$

[103] In each second stage **52**, the second central member **32** and all offset members **33** are engaged whereby they rotate in a common direction and provide the following speed ratios:

$$R_2 = 1 - \frac{P_o}{P_2} : 1 \quad R'_2 = \frac{P_2}{P_2 - P_o} : 1$$

[104] The following speed ratios result when the following conditions are met:

$$\begin{aligned} R'_2 &= P_2 : 1 & P_o &= P_2 - 1 \\ R'_2 &= -P_2 A & P_o &= P_2 + 1 \end{aligned}$$

[105] The following speed ratios result when the coupling members **34** are stepped:

$$R_2 = 1 - \frac{P_o P_b}{P_2 P_a} : 1 \quad R'_2 = \frac{P_2 P_a}{P_2 P_a - P_o P_b} : 1$$

[106] The following speed ratios result when the following conditions are met:

$$\begin{aligned} R'_2 &= P_2^2 : 1 & P_o &= P_2 - 1 & P_a &= P_2 & P_b &= P_2 + 1 \\ R'_2 &= P_2^2 : 1 & P_o &= P_2 + 1 & P_A &= P_2 & P_B &= P_2 - 1 \end{aligned}$$

[107] A first example considers the first and second exemplary embodiments illustrated in Figs 1-2 where each coupling member **34** is a non-stepped pinion gear.

$$P_1 = 27 \quad P_2 = 21 \quad P_o = 20$$

$$R_1 = 1 + \frac{P_o}{P_1} = 1.74 : 1 \quad R'_2 = P_2 = 21 : 1 \quad R = R_1 R'_2 = 37 : 1$$

[108] A second example considers the third exemplary embodiment illustrated in Fig 3 where each coupling member **34** is a stepped pinion gear.

$$P_1 = 25 \quad P_2 = 19 \quad P_o = 20 \quad P_a = 19 \quad P_b = 18$$

$$R_1 = 1 + \frac{P_o}{P_1} = 1.8 : 1 \quad R'_2 = P_2^2 = 361 : 1 \quad R = R_1 R'_2 = 650 : 1$$

[109] A third example considers the seventh exemplary embodiment illustrated in Fig 7 where all engaging members in the second stage **52** are pulleys and belts. The absence of gear teeth makes a very high reduction ratio practical. Note that if  $P_2 = P_o$  then  $R = R_2' = \infty : 1$ .

$$P_1 = 19 \quad P_2 = 20.1 \quad P_o = 20$$

$$R_1 = 1 + \frac{P_o}{P_1} = 2.05 : 1 \quad R'_2 = \frac{P_2}{P_2 - P_o} = 201 : 1 \quad R = R_1 R'_2 = 413 : 1$$

[110] A fourth example considers the second stage **52** of the ninth exemplary embodiment illustrated in Fig 9. The second central member **32** and the offset member third step **33c** have a variable pitch radius defined by the ratio  $N$ . In practice, the pitch diameters of the offset member **33c** and the second central member **32** may be manipulated to maintain a constant length of the flexible coupling member **34b**. The variable pitch second stage **52** provides the following speed ratios:

$$R_2 = 1 - N : 1 \quad R'_2 = \frac{1}{1-N} : 1 \quad N = \frac{P_o}{P_2}$$

[111] When  $N$  varies from 0.5 to 1,  $R_2'$  varies from 2:1 to  $\infty$ :1, which corresponds to a stopped

second drive-shaft **12** ( $T_2=0$  for any  $T_0$ ). When **N** varies from 1 to 2,  $R_2'$  varies from  $\infty:1$  to  $-1:1$  which corresponds to a direction reversal of the second drive-shaft **12**.

$$N = \frac{1}{2} \rightarrow 1 \quad \beta_4 = 2:1 \rightarrow \infty:1$$

$$N = 1 \rightarrow 2 \quad R_2' = \infty:1 \rightarrow -1:1$$

[112] A fifth example considers the tenth and eleventh exemplary embodiments illustrated in Figs 10-11 which depict a Coupled Orbitless gearbox.

$$P_2 = 2 \setminus P_0 = 20$$

$$R = R_2' = P_2 = 2 \setminus A$$

**ADVANTAGES**

- [113] The exemplary embodiments disclosed herein have a number of advantageous properties.
- [114] Certain exemplary embodiments comprise two gearing stages with a single set of carriers which provides low cost and complexity.
- [115] Certain exemplary embodiments provide a high speed ratio in a small volume.
- [116] Certain exemplary embodiments provide multiple speed ratios.
- [117] Certain exemplary embodiments provide an infinitely variable speed ratio.
- [118] Certain exemplary embodiments provide low pitch velocity and bearing speed which may accommodate a high input speed.
- [119] Certain exemplary embodiments comprise flexible coupling members with a high contact ratio and high torque capacity.
- [120] Certain exemplary embodiments comprise offset or co-axial drive axes.
- [121] Other advantages are apparent from the disclosure herein.

**CLAIMS**

## 1. An apparatus comprising:

a reference member, a first and second carrier, a second central member, one or more offset members, one or more coupling members, and a number of coupling axes equal to the number of coupling members;

the second central member and all offset and coupling members are engaging members;

the reference member comprises a central axis and a first and second carrier axis;

each carrier comprises a rotation axis and a number of offset axes equal to the number of offset members;

each offset member comprises a first and second member axis;

and wherein:

all axes are parallel;

the first and second carrier axes are spaced apart by a carrier distance;

all associated first and second member axes are spaced apart by the carrier distance;

each offset axis and the associated rotation axis are spaced apart by an offset distance;

all offset axes are arranged circumferentially around the associated rotation axis;

the second central member and the central axis are co-axial and rotatably coupled;

the first rotation axis and the first carrier axis are co-axial and rotatably coupled;

the second rotation axis and the second carrier axis are co-axial and rotatably coupled;

each first member axis and a different first offset axis are co-axial and rotatably coupled;

each second member axis and a different second offset axis are co-axial and rotatably coupled;

each coupling member and a different coupling axis are co-axial and rotatably coupled;

and the coupling axes are arranged whereby the coupling members simultaneously engage the second central member and all offset members.

2. The apparatus of claim 1 further comprising a first central member which is an engaging member which is co-axial and rotatably coupled with the central axis.
3. The apparatus of claim 2 wherein the first central member simultaneously engages all offset members.
4. The apparatus of claim 2 wherein the first central member simultaneously engages all coupling members.
5. The apparatus of claim 1 wherein each offset member is a stepped engaging member.
6. The apparatus of claim 1 wherein each coupling member is a stepped engaging member.
7. The apparatus of claim 1 wherein one of the first or second carriers and all coupling axes are integral, and the associated carrier axis and the central axis are co-axial.
8. The apparatus of claim 1 further comprising a third carrier comprising a third rotation axis, and wherein the third carrier and all coupling axes are integral, and the third rotation axis and the central axis are co-axial and rotatably coupled.
9. The apparatus of claim 1 further comprising a variable speed ratio between the second central member and the offset members.
10. An apparatus comprising:  
  
a reference member, a first and second carrier, a first and second central member, one or more offset members, and one or more coupling members;  
  
the first and second central members and all offset and coupling members are engaging members;  
  
the reference member comprises a central axis and a first and second carrier axis;

each carrier comprises a rotation axis and a number of offset axes equal to the number of offset members;

each offset member comprises a first and second member axis;

and wherein:

all axes are parallel;

the first and second carrier axes are spaced apart by a carrier distance;

all associated first and second member axes are spaced apart by the carrier distance;

each offset axis and the associated rotation axis are spaced apart by an offset distance;

all offset axes are arranged circumferentially around the associated rotation axis;

the first central member and the central axis are co-axial and rotatably coupled;

the second central member and the central axis are co-axial and rotatably coupled;

the first rotation axis and the first carrier axis are co-axial and rotatably coupled;

the second rotation axis and the second carrier axis are co-axial and rotatably coupled;

each first member axis and a different first offset axis are co-axial and rotatably coupled;

each second member axis and a different second offset axis are co-axial and rotatably coupled;

the first central member simultaneously engages all offset members;

and the coupling members simultaneously engage the second central member and all offset members.

11. The apparatus of claim 10 wherein each offset member is a stepped engaging member.
12. The apparatus of claim 10 further comprising a variable speed ratio between the second central member and the offset members.



13. A method comprising:

- providing a reference member, a first and second carrier, a first and second central member, one or more offset members, and one or more coupling members;
- providing the first and second central members and all offset and coupling members with an engaging means;
- providing the reference member with a central axis and a first and second carrier axis;
- providing each carrier with a rotation axis and a number of offset axes equal to the number of offset members;
- providing each offset member with a first and second member axis;
- locating all axes whereby they are all parallel;
- spacing the first and second carrier axes apart by a carrier distance;
- spacing all associated first and second member axes apart by the carrier distance;
- spacing each offset axis and the associated rotation axis apart by an offset distance;
- arranging all offset axes circumferentially around the associated rotation axis;
- co-axially locating and rotatably coupling the first central member and the central axis;
- co-axially locating and rotatably coupling the second central member and the central axis;
- co-axially locating and rotatably coupling the first rotation axis and first carrier axis;
- co-axially locating and rotatably coupling the second rotation axis and second carrier axis;
- co-axially locating and rotatably coupling each first member axis and a different first offset axis;
- co-axially locating and rotatably coupling each second member axis and a different second offset axis;

- and simultaneously engaging the coupling members with the second central member and all offset members.
14. The method of claim 13 simultaneously engaging the first central member and all offset members.
  15. The method of claim 13 simultaneously engaging the first central member and all coupling members.
  16. The method of claim 13 further providing each offset member with a first engaging step and a second engaging step.
  17. The method of claim 13 further providing each coupling member with a first engaging step and a second engaging step.
  18. The method of claim 13 further providing one of the first or second carriers with a number of coupling axes equal to the number of coupling members, co-axially locating and rotatably coupling each coupling member and a different coupling axis, and co-axially locating the associated carrier axis and the central axis.
  19. The method of claim 13 further providing a third carrier, providing the third carrier with a third rotation axis and a number of coupling axes equal to the number of coupling members, co-axially locating and rotatably coupling each coupling member and a different coupling axis, and co-axially locating and rotatably coupling the third rotation axis and the central axis.
  20. The method of claim 13 further providing a variable speed ratio between the second central member and the offset members.

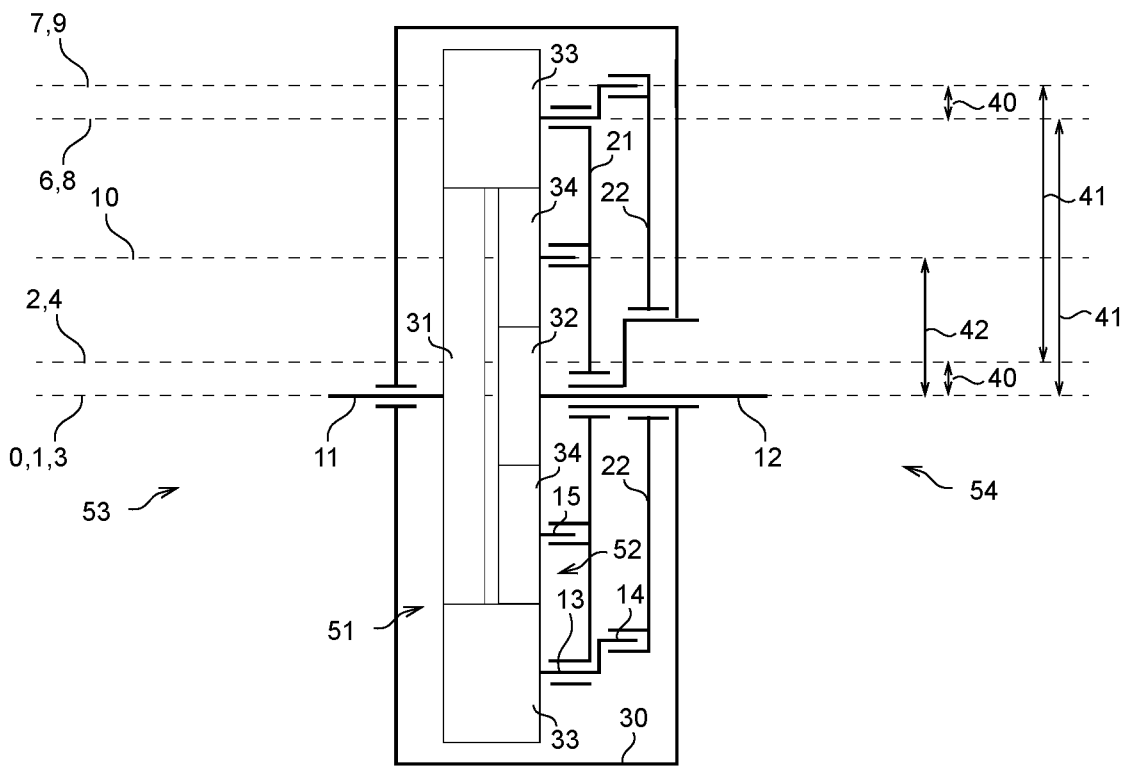

Fig. 1A

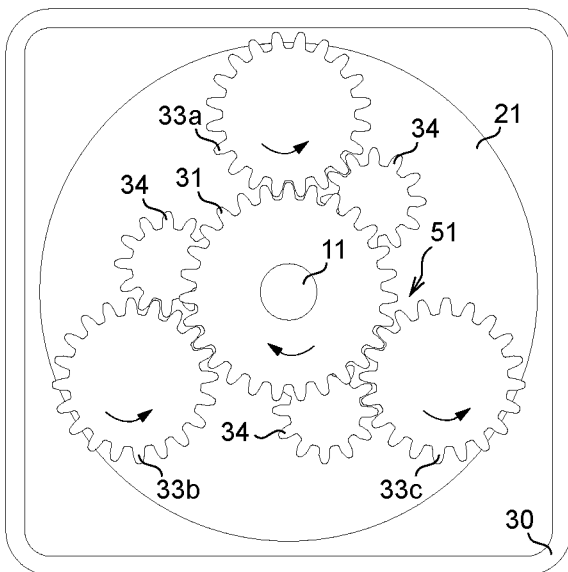

Fig. 1B

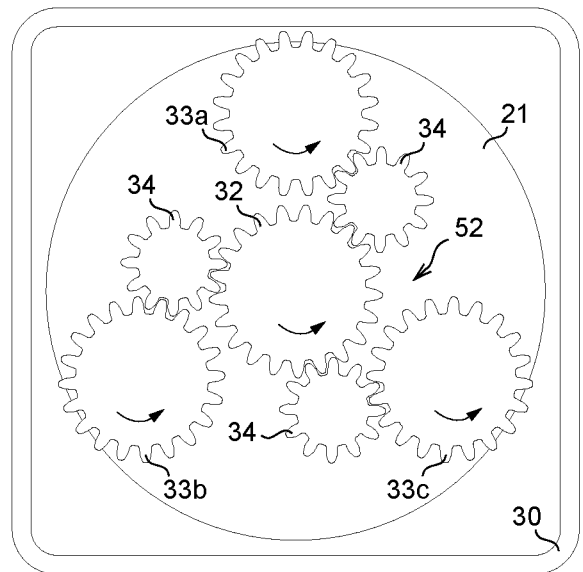

Fig. 1C

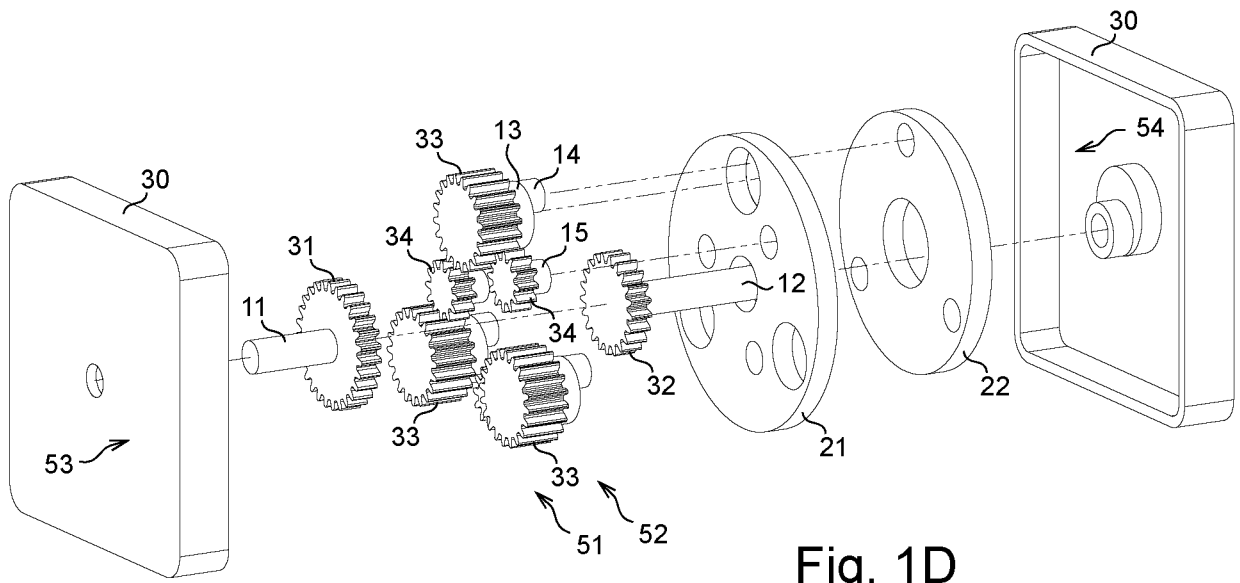

Fig. 1D

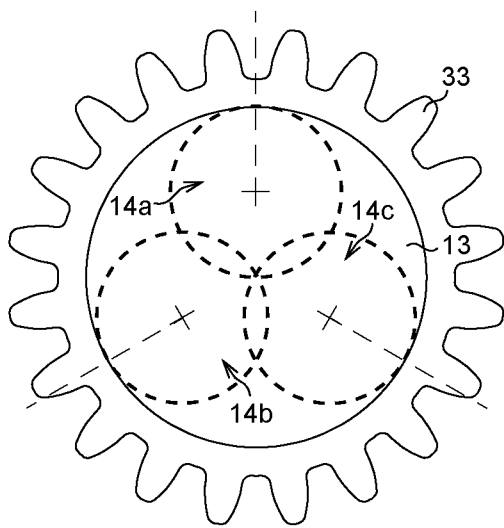

Fig. 1E

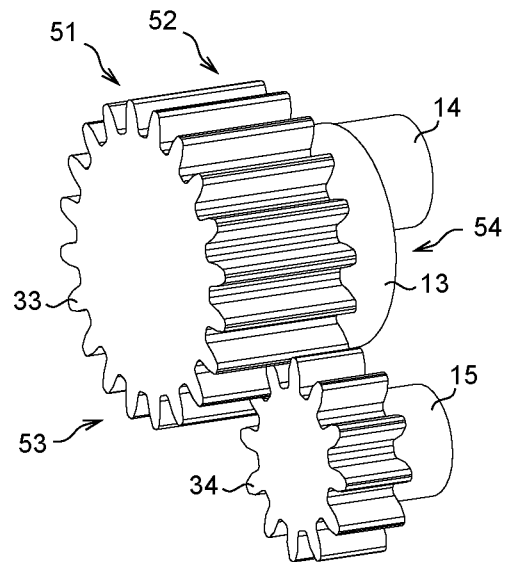

Fig. 1F

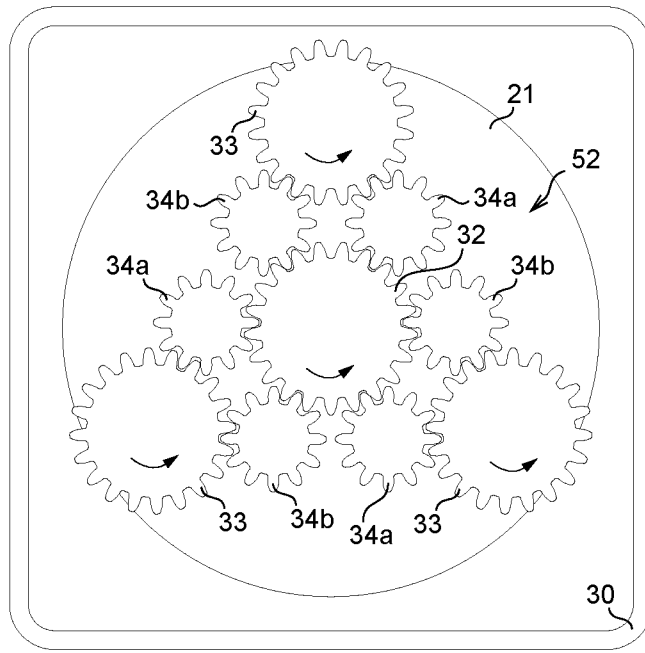

Fig. 2

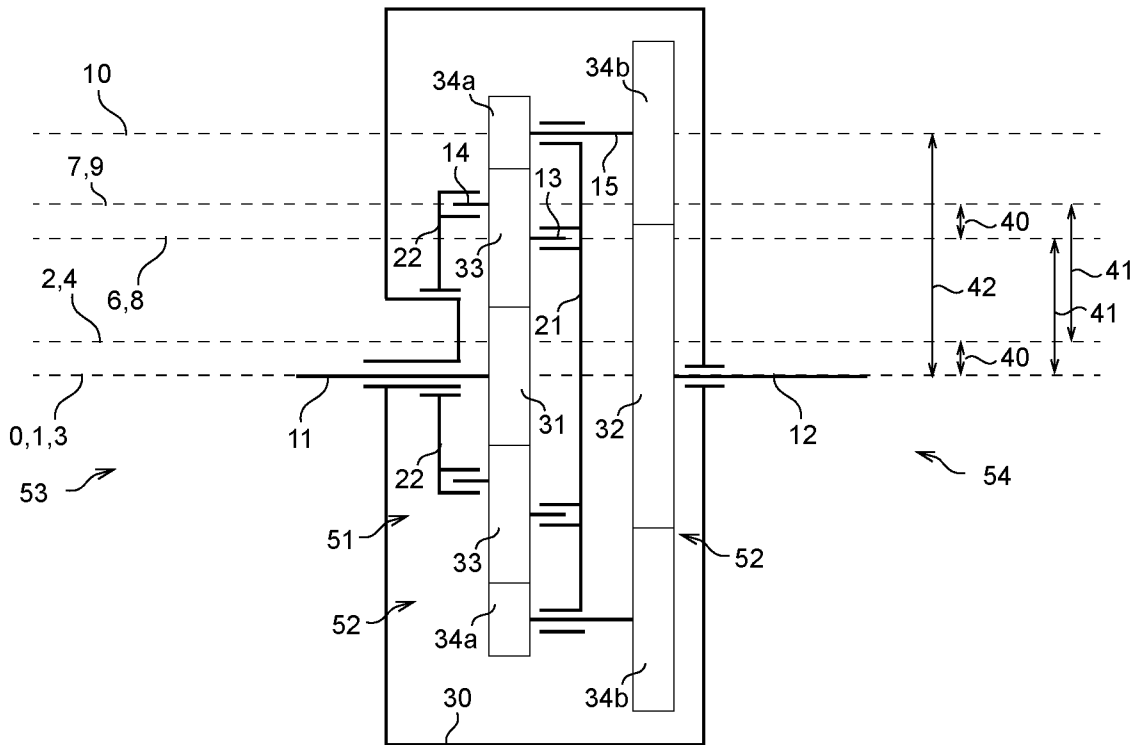

Fig. 3A

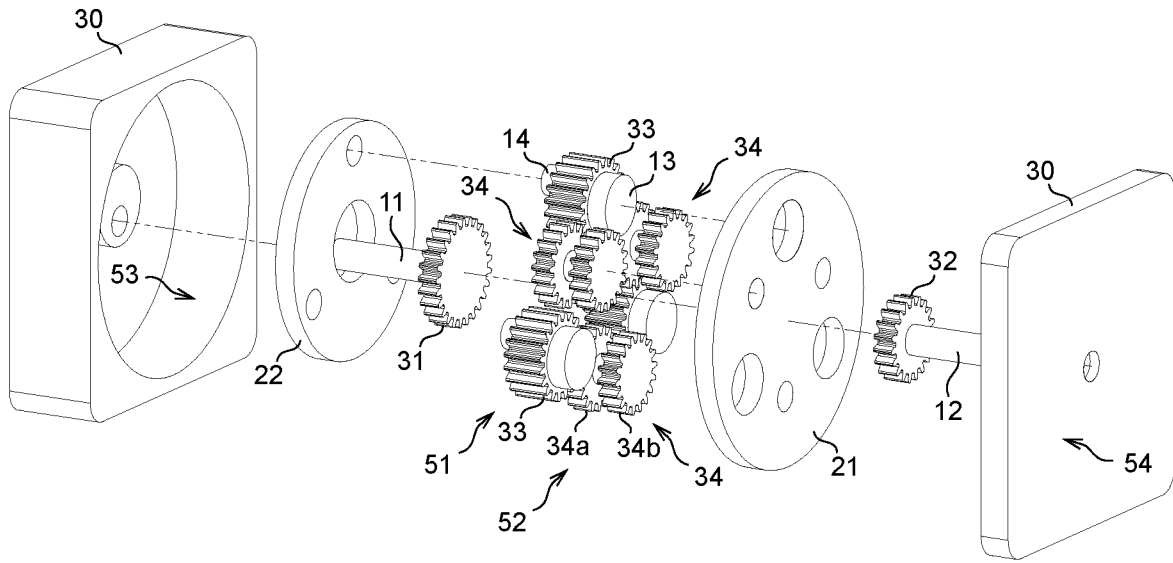

Fig. 3B

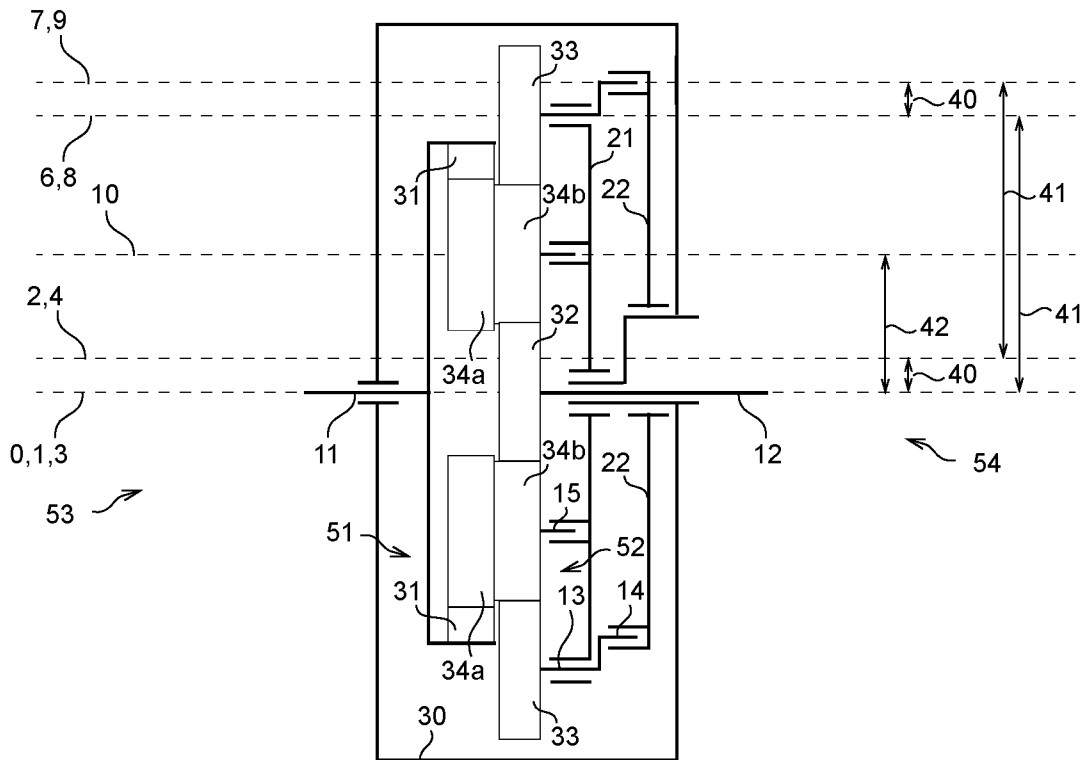

Fig. 4

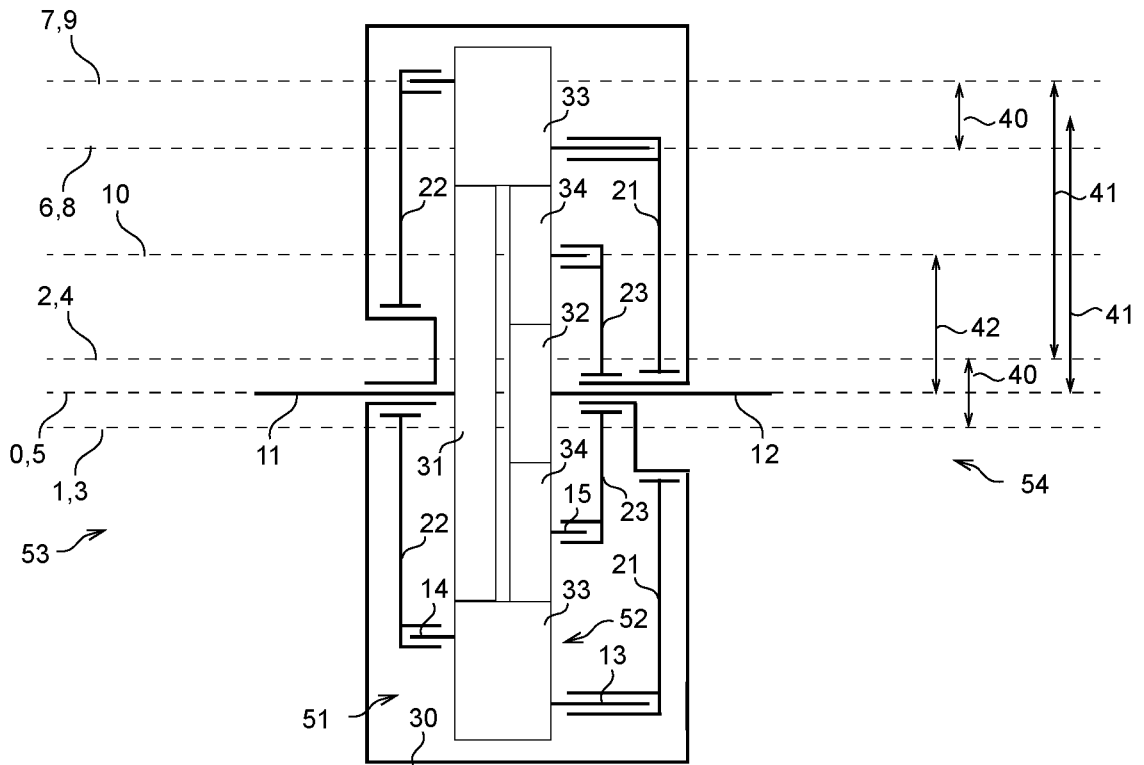

Fig. 5

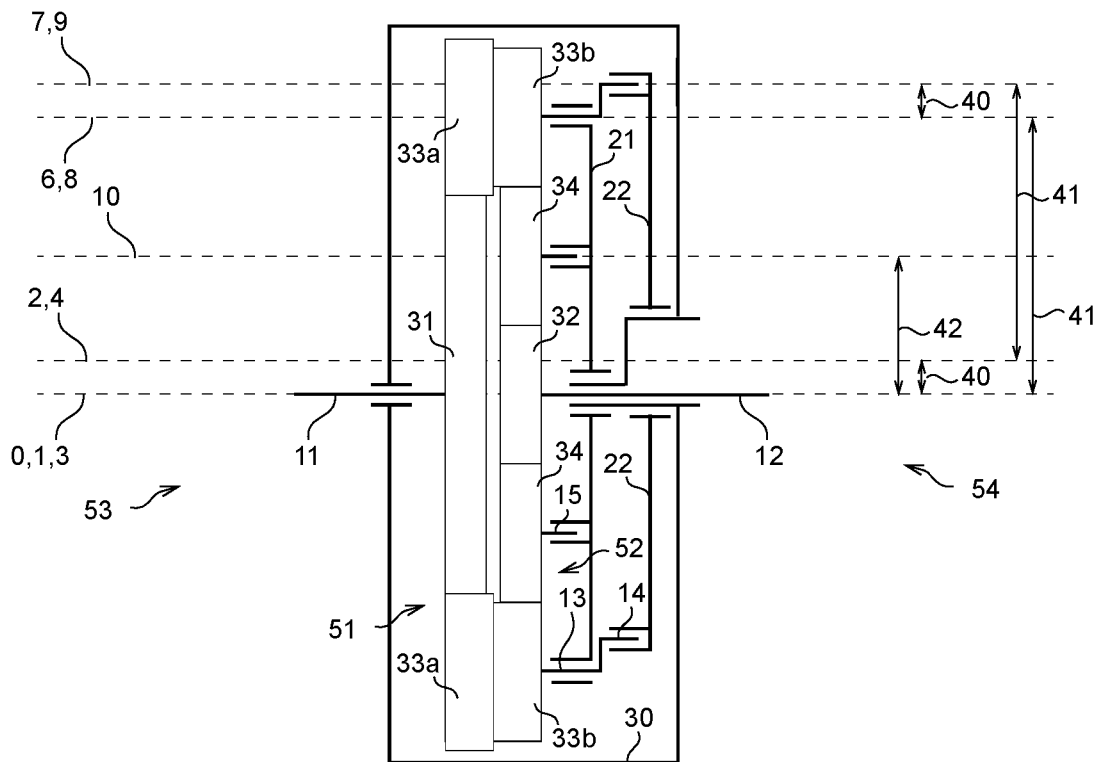

Fig. 6

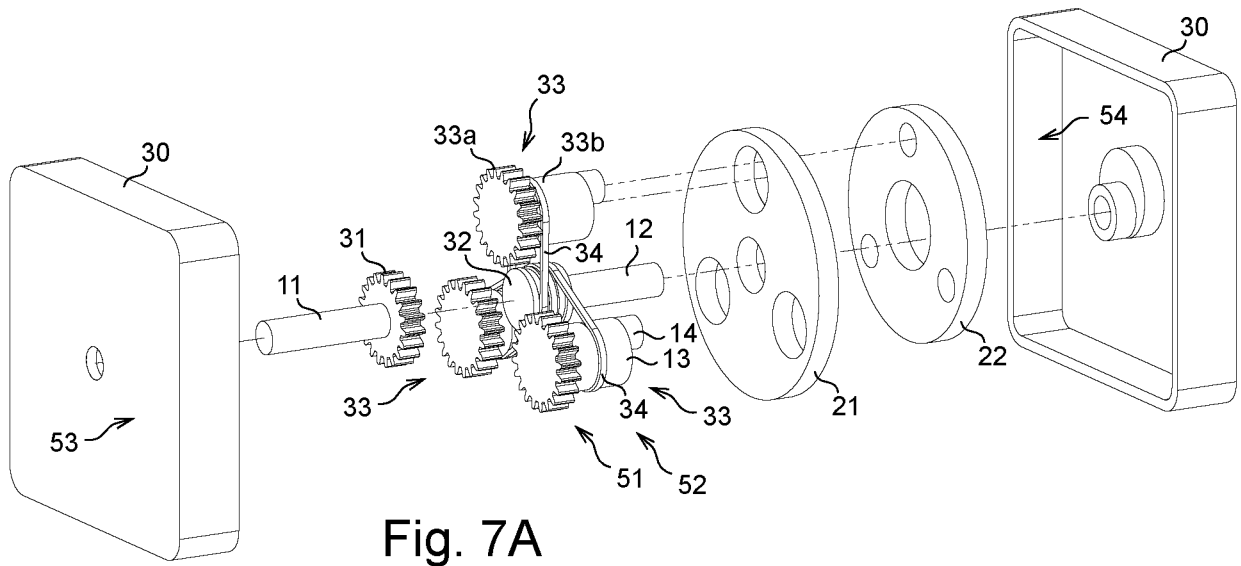

Fig. 7A

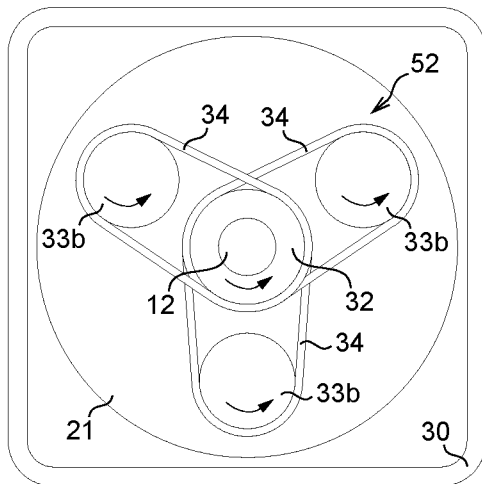

Fig. 7B

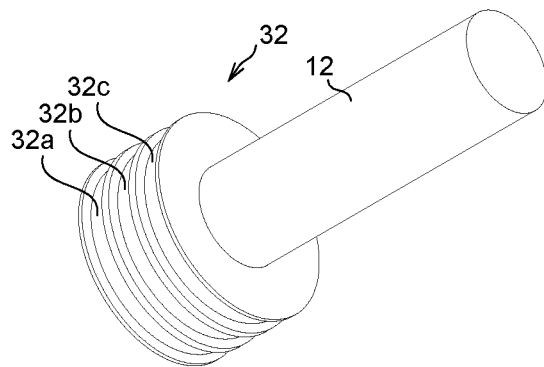

Fig. 7C

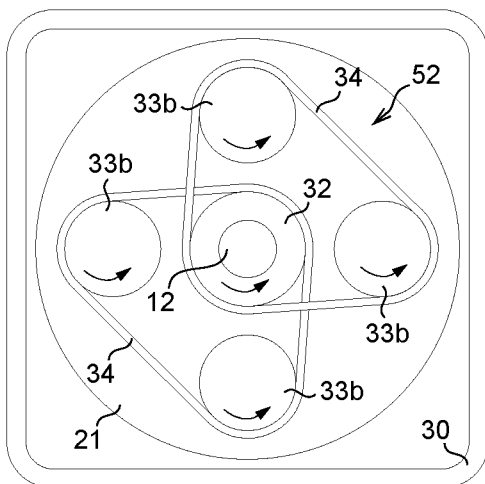

Fig. 8

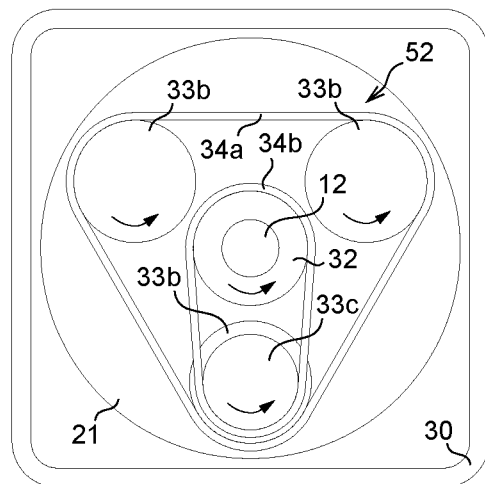

Fig. 9



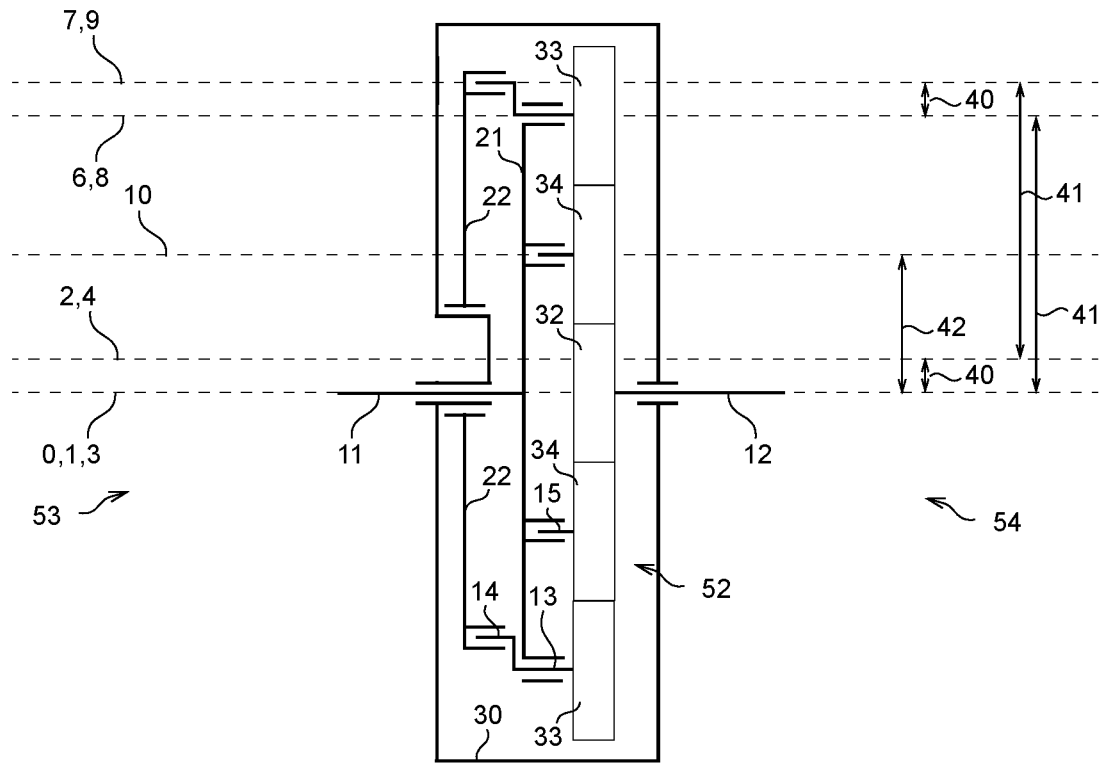

Fig. 10A

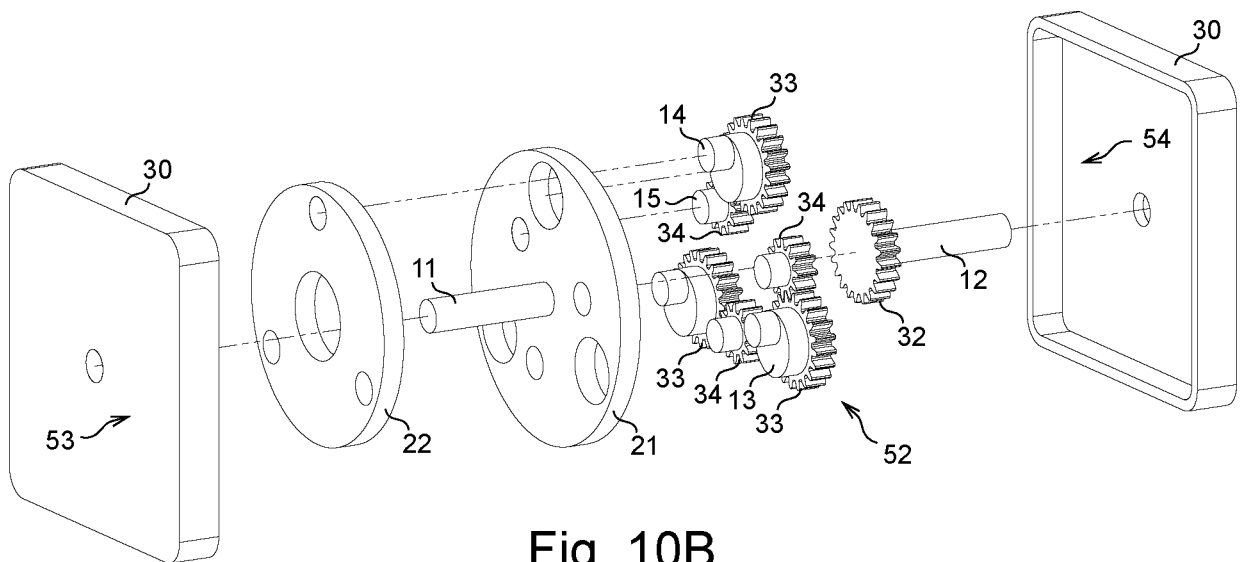

Fig. 10B

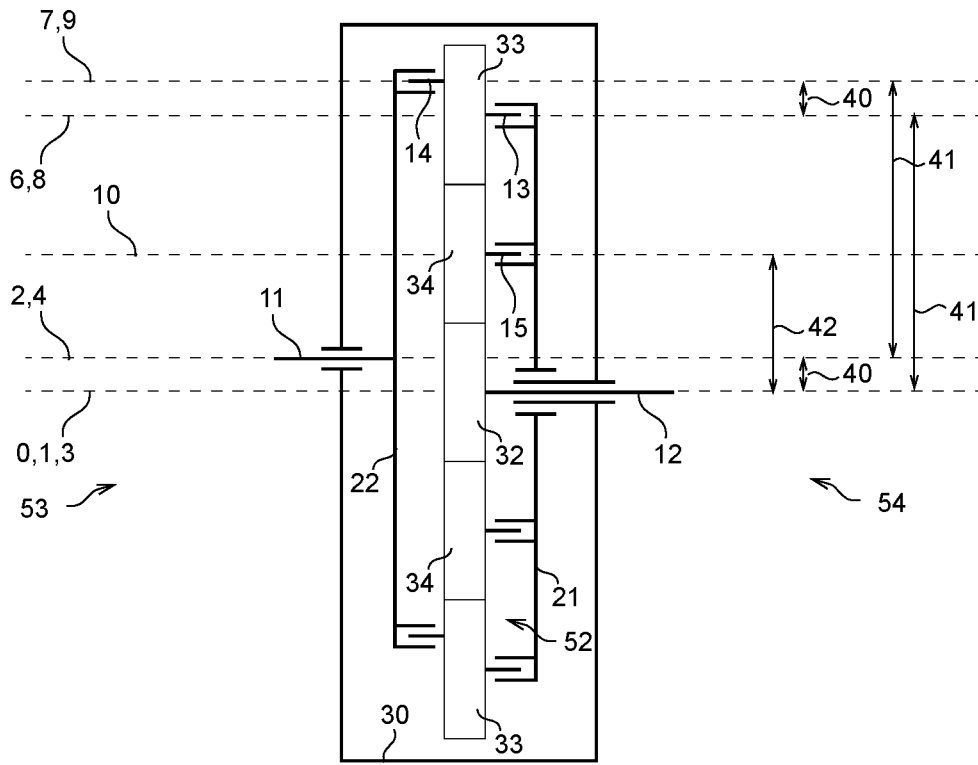

Fig. 11

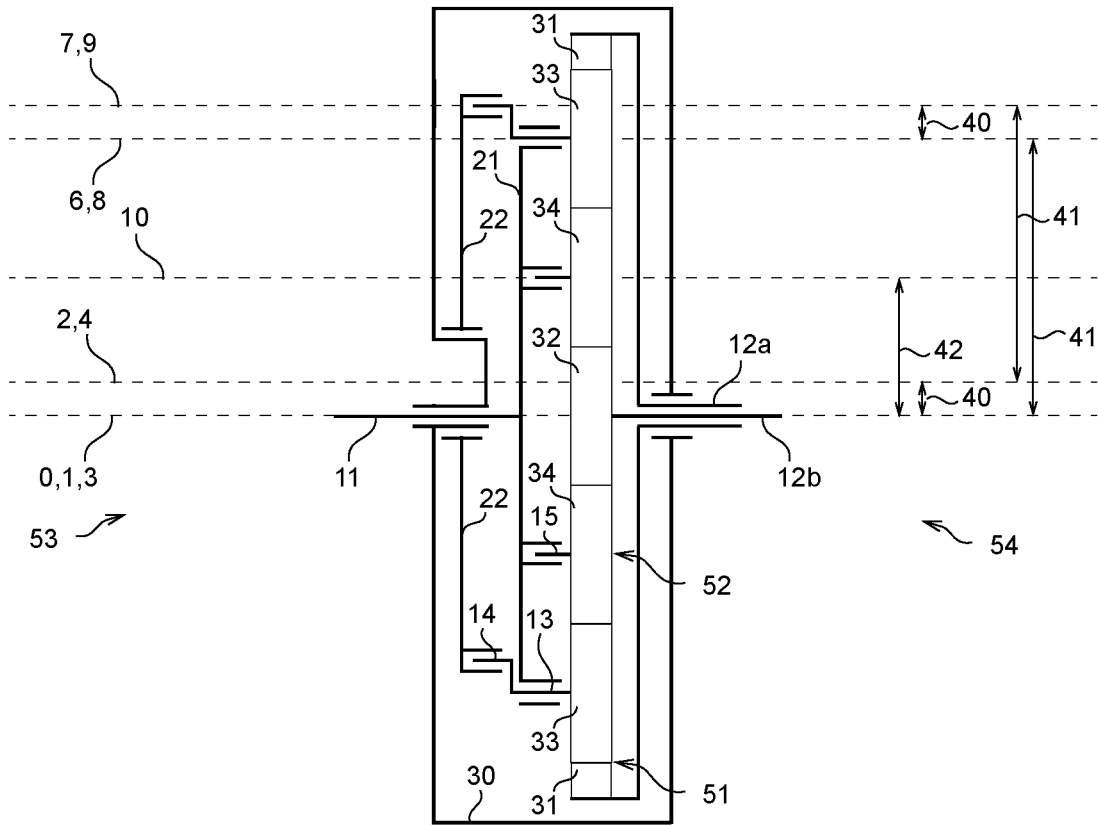

Fig. 12

## INTERNATIONAL SEARCH REPORT

International application No.

**PCT/CA2015/050861**

A. CLASSIFICATION OF SUBJECT MATTER  
 IPC: *F16H 1/02* (2006.01) , *F16H 1/20* (2006.01) , *F16H 57/02* (2012.01)

According to International Patent Classification (IPC) or to both national classification and P C

## B. FIELDS SEARCHED

Minimum documentation searched (classification system followed by classification symbols)

*F16H 1/02* (2006.01) , *F16H 1/20* (2006.01) , *F16H 57/02* (2012.01)

Documentation searched other than minimum documentation to the extent that such documents are included in the fields searched  
 none

Electronic database(s) consulted during the international search (name of database(s) and, where practicable, search terms used)

Questel-Orbit (FamPat Database), Intellect (Canadian Patent Database)

Keywords: transmission, orbit, carrier, gearbox, offset, planet, eccentric and parallel.

## C. DOCUMENTS CONSIDERED TO BE RELEVANT

Category*	Citation of document, with indication, where appropriate, of the relevant passages	Relevant to claim No.
A	US5544539 A (Spridco et al.) 13 August 1996 (13-08-1996); *whole document*	
A	US7641579 B2 (Junkers) 5 January 2010 (05-01-2010); *whole document*	
A	US2014/0200109 A1 (Stocco) 17 July 2014 (17-07-2014) *whole document*	
A	WO2013/125023 A1 (Kubota et al.) 29 August 2013 (29-08-2013). *whole document*	

Further documents are listed in the continuation of Box C.

See patent family annex.

* "A" "E" "L" "O" "P"	Special categories of cited documents: document defining the general state of the art which is not considered to be of particular relevance earlier application or patent but published on or after the international filing date document which may throw doubts on priority claim(s) or which is cited to establish the publication date of another citation or other special reason (as specified) document referring to an oral disclosure, use, exhibition or other means document published prior to the international filing date but later than the priority date claimed	"T" "X" "Y" "&"	later document published after the international filing date or priority date and not in conflict with the application but cited to understand the principle or theory underlying the invention document of particular relevance; the claimed invention cannot be considered novel or cannot be considered to involve an inventive step when the document is taken alone document of particular relevance; the claimed invention cannot be considered to involve an inventive step when the document is combined with one or more other such documents, such combination being obvious to a person skilled in the art document member of the same patent family
Date of the actual completion of the international search 10 December 2015 (10-12-2015)		Date of mailing of the international search report 21 December 2015 (21-12-2015)	
Name and mailing address of the ISA/CA Canadian Intellectual Property Office Place du Portage I, CI 14 - 1st Floor, Box PCT 50 Victoria Street Gatineau, Quebec K1A 0C9 Facsimile No.: 001-819-953-2476		Authorized officer  Sorin Muntean (819) 639-7875	

**INTERNATIONAL SEARCH REPORT**  
Information on patent family members

International application No.  
**PCT/CA2015/050861**

Patent Document Cited in Search Report	Publication Date	Patent Family Member(s)	Publication Date
US5544539A	13 August 1996 (13-08-1996)	None	
US7641 579B2	05 January 2010 (05-01-2010)	US2008261 743A1 AU200721 1864A1 AU200721 1864B2 BRPI0800882A2 CN10 1290041 A CN10 1290041 B CZ20070557A3 DE1 02007061 322A1 DK200701 500A EA2008001 26A1 EA01 3274B1 ES2347508A1 ES2347508B2 FR291 5257A1 FR291 5257B1 GB0807043D0 GB2448609A GB2448609B ITMI20071 966A1 JP2008267596A KR20080094535A MX200701 6390A NL2001 437A1 NL2001 437C NO20075558A PL384979A1 PL212387B1 SE0800309L SE532895C2 TW200842265A TWI338751 B ZA200707299A	23 October 2008 (23-10-2008) 06 November 2008 (06-11-2008) 25 March 2010 (25-03-2010) 02 December 2008 (02-12-2008) 22 October 2008 (22-10-2008) 30 May 2012 (30-05-2012) 29 October 2008 (29-10-2008) 30 October 2008 (30-10-2008) 20 October 2008 (20-10-2008) 30 October 2008 (30-10-2008) 30 April 2010 (30-04-2010) 29 October 2010 (29-10-2010) 20 April 2012 (20-04-2012) 24 October 2008 (24-10-2008) 20 April 2012 (20-04-2012) 21 May 2008 (21-05-2008) 22 October 2008 (22-10-2008) 14 July 2010 (14-07-2010) 20 October 2008 (20-10-2008) 06 November 2008 (06-11-2008) 23 October 2008 (23-10-2008) 16 February 2009 (16-02-2009) 21 October 2008 (21-10-2008) 01 March 2011 (01-03-2011) 20 October 2008 (20-10-2008) 27 October 2008 (27-10-2008) 28 September 2012 (28-09-2012) 20 October 2008 (20-10-2008) 04 May 2010 (04-05-2010) 01 November 2008 (01-11-2008) 11 March 2011 (11-03-2011) 25 September 2008 (25-09-2008)
US201 4200109A1	17 July 2014 (17-07-2014)	None	
WO201 3125023A1	29 August 2013 (29-08-2013)	WO201 3125023A1 CN1034771 18A EP281 8758A1 KR201 401 28858A US201 4031 165A1 US8900091 B2	29 August 2013 (29-08-2013) 25 December 2013 (25-12-2013) 31 December 2014 (31-12-2014) 06 November 2014 (06-11-2014) 30 January 2014 (30-01-2014) 02 December 2014 (02-12-2014)