

WAVETEK[®] **Meterman[™]**

Operator's Manual

FG2C/FG3C **Function Generator**

- Bedienungsanleitung
- Manual de Instrucciones
- Manuel d'Utilisation

Bench Instrument

FG2C/FG3C Function Generator

WARRANTY

The FG2C and FG3C Function Generators are warranted against any defects of material or workmanship within a period of one (1) year following the date of purchase of the Function Generator by the original purchaser or original user. Any Function Generator claimed to be defective during the warranty period should be returned with proof of purchase to a Wavetek authorized Service Center or to the local Wavetek dealer or distributor where the Function Generator was purchased. See maintenance section for details. Any implied warranties arising out of the sale of a Wavetek Function Generator, including but not limited to implied warranties of merchantability and fitness for a particular purpose, are limited in duration to the above stated one (1) year period. Wavetek shall not be liable for loss of use of the Function Generator or other incidental or consequential damages, expenses, or economical loss or for any claim or claims for such damage, expenses or economical loss. Some states do not allow limitations on how long implied warranties last or the exclusion or limitation of incidental or consequential damages, so the above limitations or exclusions may not apply to you. This warranty gives you specific legal rights, and you may also have other rights that vary from state to state.

CERTIFICATIONS AND PRECAUTIONS

This instrument is EN61010-1:1993 certified for Installation Category II, Pollution Degree II. All inputs are protected against continuous overload conditions up to the limits of each function's stated input protection (see specifications). Never exceed these limits or the ratings marked on the instrument itself. Always inspect your Function Generator, test leads and accessories for signs of damage or abnormality before every use. If an abnormal condition exists (broken or damaged test leads, cracked case, display not reading, etc.), do not use. Never ground yourself when taking measurements. Do not touch exposed metal pipes, outlets, fixtures, etc., which might be at ground potential. Keep your body isolated from ground and never touch exposed wiring, connections, test probe tips, or any live circuit conductors. Do not operate instrument in an explosive atmosphere (flammable gases, fumes, vapor, dust.) Do not use this or any piece of test equipment without proper training.



DANGER High Voltage



WARNING: To avoid electrical shock, the power cord protective grounding conductor must be connected to ground.



ATTENTION Refer to Manual



CAUTION: To avoid damaging the instrument, do not use it in a place where ambient temperature exceeds 40°C.



Protective Conductor Terminal



CAUTION: To avoid damaging the instrument, do not input more than 15VDC to VCF.



Frame or Chassis Terminal



CAUTION: To avoid damaging the instrument, do not input more than 150VAC to Frequency Counter (FG3C only).



CAUTION: To avoid damaging the instrument, do not input more than 10Vpp during EXT modulation operation (FG3C only).

FOR UNITED KINGDOM ONLY

NOTE: This lead/appliance must only be wired by competent persons

WARNING: THIS APPLIANCE MUST BE EARTHED

IMPORTANT: The wires in this lead are coloured in accordance with the following code:

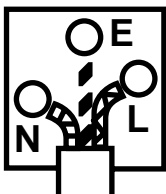

Green/Yellow Earth

Blue Neutral

Brown: Live (Phase)

As the colours of the wires in main leads may not correspond with the colours marking identified in your plug/appliance, proceed as follows:

The wire which is coloured Green & Yellow must be connected to the Earth terminal marked with the letter E or by the earth symbol \oplus or coloured Green or Green & Yellow.

The wire which is coloured Blue must be connected to the terminal which is marked with the letter N or coloured Blue or Black.

The wire which is coloured Brown must be connected to the terminal marked with the letter L or P or coloured Brown or Red.

If in doubt, consult the instructions provided with the equipment or contact the supplier. This cable/appliance should be protected by a suitably rated and approved HBC mains fuse : refer to the rating information on the equipment and/or user instructions for details. As a guide, cable of 0.75mm should be protected by a 3A or 5A fuse. Larger conductors would normally require 13A types, depending on the connection method used.

Any moulded mains connector that requires removal /replacement must be destroyed by removal of any fuse & fuse carrier and disposed of immediately, as a plug with bared wires is hazardous if engaged in a live socket. Any rewiring must be carried out in accordance with the information detailed on this label.

CONTENTS

	page		page
Warranty	1	Control Descriptions	5
Certifications and Precautions	1	Using the Function Generator	5
Safety Information	1	Maintenance and Repair	8
Introduction	2	Specifications	9

PREPARATION FOR USE – UNPACKING

Your shipping carton should include the Function Generator, 1 meter long BNC to mini- alligator clip test lead, one power cord, one spare fuse, and this manual. If any of the items are damaged or missing, immediately return the complete package to the place of purchase for an exchange.

INTRODUCTION

The FG2C and FG3C Function Generators are stable low distortion instruments that generate sine, triangle, and square waveforms in frequencies up to 3 MHz. The FG2C has amplitude, offset, and duty cycle controls. The outputs are Main(50Ω) and logic(TTL and CMOS). The FG3C has the same capabilities plus internal Sweep(Log/Linear), Modulation (AM/FM), external VCF/MOD and counter inputs and GCV output. The counter can be switched to measure and display the frequency of an external signal up to 150 MHz.

FEATURES COMPARISON TABLE FOR MODELS:

FEATURE / MODEL	FG2C	FG3C
AM/FM modulation	na	X
SWEEP control	na	X
COUNTER input	na	X
GCV Output	na	X
TTL/CMOS output	X	X
VCF input	X	X
Duty Cycle Control	X	X

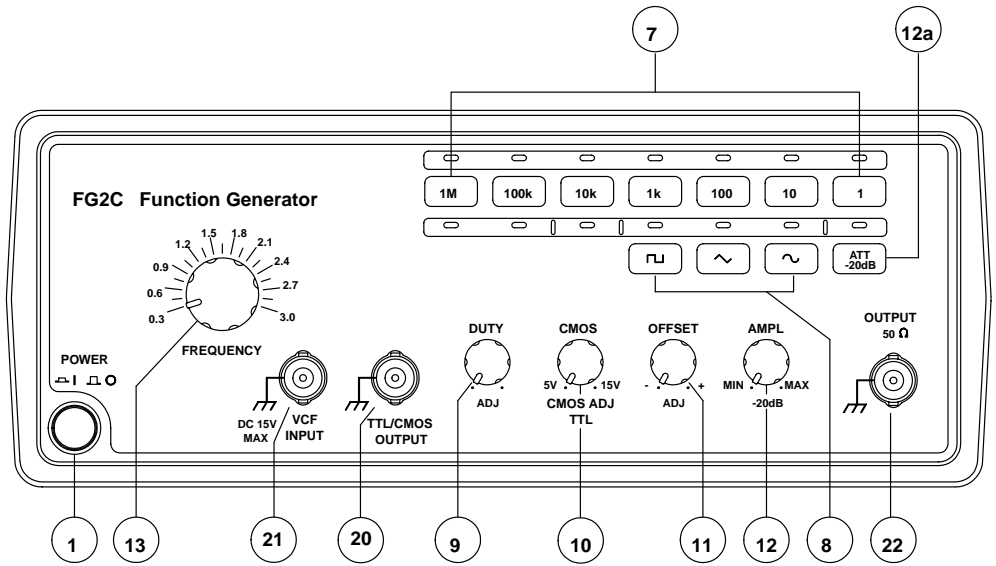

Fig. 1 FG2C Front Panel

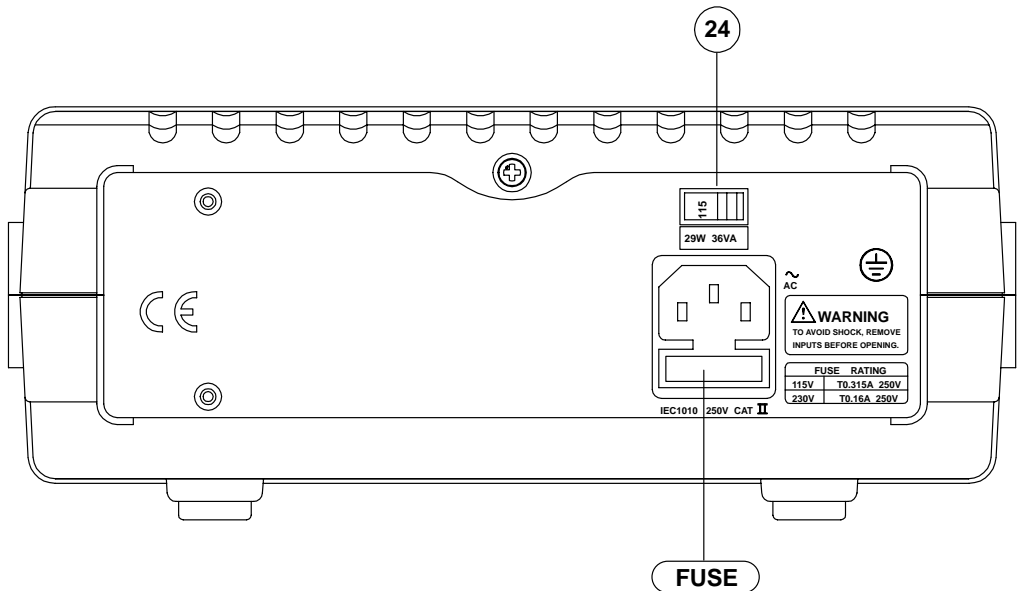

Fig. 2 FG2C Rear Panel

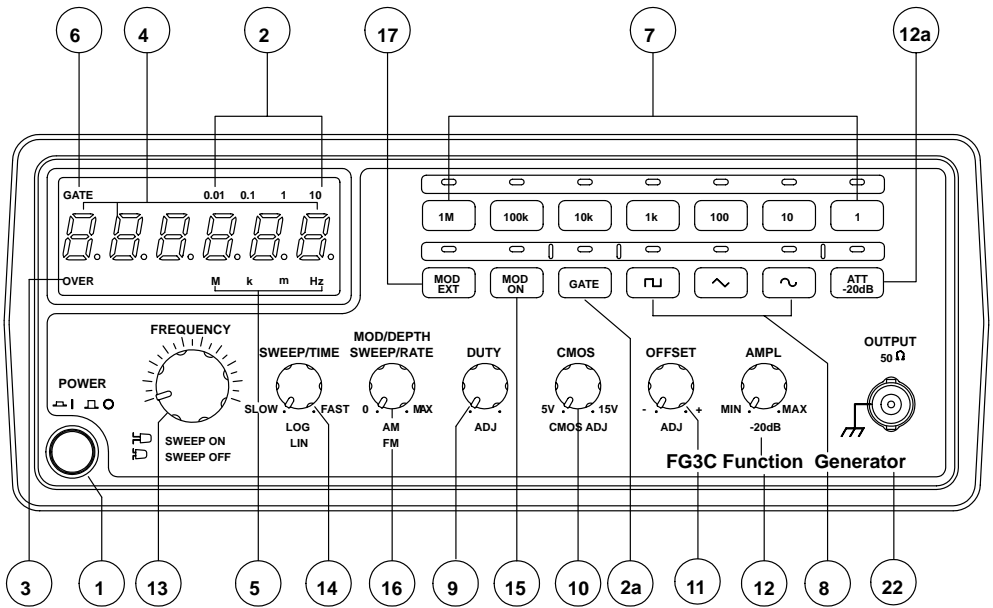

Fig. 3 FG3C Front Panel

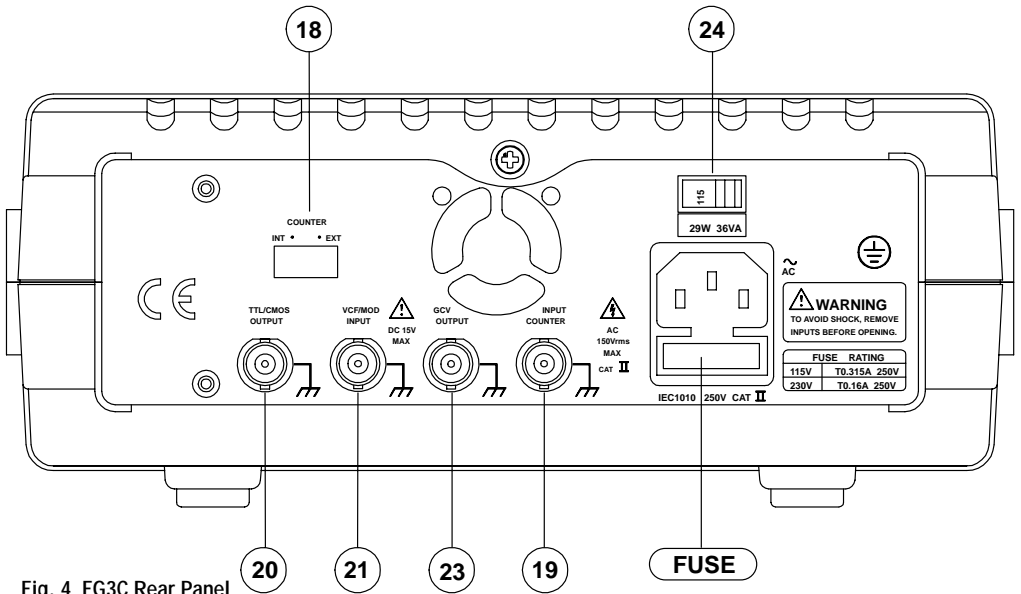

Fig. 4 FG3C Rear Panel

CONTROL DESCRIPTIONS

FRONT PANEL

1. **Power Switch**
Applies line power to the FG2C\FG3C power supply.
2. **Gate Time Indicator**
Gate interval indicator (the gate interval of internal counter is 0.01 second).
- 2a. **Gate Time Selector**
Press this button to change gate time when use EXternal counter mode. The sequence is 0.01s, 0.1s, 1s, or 10s selected by pressing this button.
3. **Over Range Indicator**
In the external counter mode, the indicator is illuminated when the output frequency is greater than the range selected.
4. **Counter Display**
Shows the external frequency via a 6 digit green display, and the internal frequency via a 5 digit green display.
5. **Frequency Indicator**
Indicates the current frequency value multiplier.
6. **Gate Time Indicator**
Flashes at the beginning of each gating interval.
7. **Frequency Range Selector**
Select the required frequency range by pressing the relevant push button on the panel as shown in Table 1 .

Push button	Frequency Range
1	0.3Hz to 3Hz
10	3Hz to 30Hz
100	30Hz to 300Hz
1k	300Hz to 3kHz
10k	3kHz to 30kHz
100k	30kHz to 300kHz
1M	300kHz to 3MHz

8. **Function Selector**
Press one of the three push buttons to select the desired output waveform.
9. **Duty Function**
Pull out and rotate the knob to adjust the duty cycle of the waveform.
10. **TTL/CMOS Selector**
When the knob is in, the **BNC terminal of (20)** will output a TTL compatible waveform. If the knob is out, rotating the knob will adjust the CMOS compatible output (5 -15Vpp) at the **BNC (20) terminal** .
11. **DC Offset Control**
Pull out the knob to select any DC level of the waveform between $\pm 10V$., turn the knob clockwise to select a positive DC offset level of the waveform and counterclockwise for a negative DC offset level of the waveform.
12. **Output Amplitude Control with Attenuation Operation**
Turn clockwise for MAX. output and counterclockwise for MIN output. Pull the knob out for additional 20dB output attenuation.
- 12a. **20dB Attenuation**
Press the button to reduce the output by 20dB .
13. **FREQ/SWEEP Selector and Frequency Adjustment**
(Sweep On/Off): Turn clockwise the knob clockwise for MAX frequency and counterclockwise for MIN frequency. (Keep the knob pointer within the scale range on the panel). Pull out the knob to start the auto sweep operation; the upper frequency limit is determined by the knob position.

14 SWEEP/TIME

Control and LIN/LOG Selector:

- (1) Rotate the knob clockwise to adjust sweep time for MAX, or counterclockwise for MIN.
- (2) Select Linear sweep mode by pushing in the knob or LOG sweep mode by pulling out the knob.

15. MOD ON/off Selector

Press the button once, the indicator will light, and the output will be modulated by internal 400Hz sinewave or press the button again, the indicator will be off, and the output will be modulated an external signal via **VCF/MOD** in connector **(21)**.

16. MOD/DEPTH

SWEEP RATE and AM/FM Selector:

- (1) Sweep width can be controlled from 0 to 1000 times.
- (2) Adjust modulation ratio by turning the knob clockwise for MAX, or counterclockwise for MIN.
- (3) Select AM(amplitude modulation) mode by pushing in the knob or FM(frequency modulation) mode by pulling out the knob.

17 MOD EXT

Selector: Press the button once, the indicator will light, and EXTERNAL MODULATION is selected. Press the button again, the indicator will be off, and INT MODULATION is selected.

FRONT or REAR PANEL

18. INT/EXT Counter Switch

Select internal counter mode (count the frequency of the FG3C output) or select EXT counter mode for an independent counter (input signal from **BNC (19) terminal**).

19. EXT. Counter Input Terminal: Accepts external signals for measurement.

20. TTL/CMOS Output Terminal

TTL/CMOS compatible signal output

21. VCF/MOD

Input Terminal: Connector for the input voltage required to perform the "voltage control frequency" operation or the EXT modulation operation.

22. Main Output Terminal

Main signal output.: The Output signal is calibrated for a 50 Ω load.

23. GCV Output

This is a DC voltage output and its voltage level will follow the change of Frequency.

24. 115/230 Switch

This switch selects the mains power voltage.

The functions of items 2, 2a, 3, 4, 5, 6, 14, 15, 16, 17, 18, 19, and 23 do not apply to model FG2C.

USAGE PROCEDURES

The following section describes the basic setup and controls for operating the functions of this instrument.

One of the best ways to observe waveforms is to connect the function generator to an Oscilloscope. Observe the effects that different controls have on the waveforms displayed on the Oscilloscope when proceeding with the following steps:

First-step check:

- (1) Ensure that the **mains voltage switch (24)** on the rear panel of this instrument of is compatible with the mains supply. Connect the instrument to the mains supply using the power cord supplied.
- (2) Press **PWR (1)** switch, ensure all the rotary knobs are pushed in, and rotate the **AMPL (12)** knob to fully counterclockwise.
- (3) Rotate the **FREQ (13)** control fully counterclockwise.

Triangle, square, and sine waves

- (1) Select the **Function (8)**, select the **Range (7)**, and rotate the **FREQUENCY (13)** knob to set the required frequency (read output in **display window (4)**).
- (2) Connect the **Output 22)** terminal to the oscilloscope for observing the waveform signal.
- (3) Rotate the **AMPL (12)** knob to control the waveform amplitude.
- (4) If attenuation of the output signal is required, pull out the **AMPL (12)** knob to obtain 20dB attenuation or press the **ATT -20dB (12a)** button for additional 20dB attenuation..
- (5) The phase-relation of Output waveform and TTL output is shown in Figure 5 below:

Figure 5

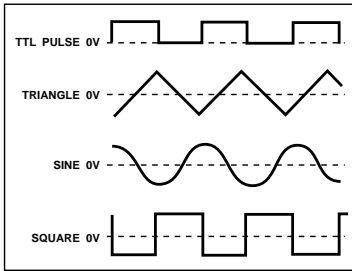

Pulse wave generation

- (1) Press the **Function (8)** button (\square), select the **Range (7)**, and rotate the **FREQUENCY (13)** knob to set the frequency.
- (2) Connect the **OUTPUT terminal (22)** to the oscilloscope for observing the output signal.
- (3) Pull out and rotate the **Duty (9)** knob to adjust the width of pulse waveform.
- (4) Adjust the **AMPL (12)** knob to control the pulse amplitude.
- (5) Pull out the **AMPL (12)** knob to attenuate the output signal by 20dB.

Ramp wave generation

- (1) Press the **Function (8)** button (∇), select the **Range (7)**, rotate the **FREQUENCY (13)** knob to set the frequency.
- (2) Connect the **OUTPUT terminal (22)** to the oscilloscope for observing the output signal.
- (3) Pull out and rotate the **Duty (9)** knob to adjust the slope of ramp waveform.
- (4) Adjust the **AMPL (12)** knob to control output amplitude of ramp waveform.
- (5) Pull out the **AMPL (12)** knob to attenuate the output signal by 20dB.

TTL/CMOS signal output

- (1) Select the **Range (7)**, and rotate the **FREQUENCY (13)** knob to set the frequency.
- (2) Connect BNC connector of **TTL/CMOS (20)** to oscilloscope to observe the output signal.
- (3) The output is a square waveform fixed at TTL level, suitable for general TTL integrated circuits.
- (4) If a square waveform of CMOS level is required, pull out the **CMOS (10)** knob and adjust to required voltage levels.

Variation of external voltage-controlled frequency(VCF)

This mode of operation allows the user to adjust the frequency of the Function Generator with an external DC control Voltage.

- (1) Select the **Function (8)**, select the **Range (7)**, and rotate the **FREQUENCY (13)** knob to set the required frequency.
- (2) Connect external control voltage ($0\pm 10VDC$) to the **VCF (21)** terminal via a suitable lead, and observe the signal generated from the **Output (22)** BNC terminal.
- (3) Other adjustments; the **AMPL (12)** knob can change the amplitude of signal, or attenuate the signal; the **Offset (11)** knob is for DC level changes, rotate the **Duty (8)** knob to change the output ratio of pulse or ramp waveform ...etc..

Auto Sweep

- (1) Select the **Function (8)** button, select the **Range (7)**, and rotate the **FREQUENCY (13)** knob to set the required base frequency.
- (2) Connect the **OUTPUT terminal (22)** to the oscilloscope for observing the OUTPUT signal.
- (3) Rotate the **FREQUENCY (13)** knob to determine the upper limit frequency.
- (4) Pull out the **FREQUENCY (13)** knob to activate auto sweep operation.
- (5) Rotate the **SWEEP/TIME (14)** knob and **SWEEP RATE (16)** knob to adjust sweep time and rate.
- (6) The LOG sweep mode is selected by pulling out the **SWEEP/TIME (14)** knob.

Note: The sweep width can only be adjusted during the sweep cycle and it cannot be stopped.

AM/FM operation

- (1) Select the **Function (8)**, select the **Range (7)**, rotate the **FREQUENCY (13)** knob to set required frequency.
- (2) Connect **OUTPUT terminal (22)** to the oscilloscope for observing the output signal.
- (3) For the FM modulation mode, press the **MOD (15)** button and pull out the **MOD/DEPTH (16)** knob.
- (4) For the AM modulation mode, press the **MOD (15)** button and push in the **MOD/DEPTH (16)** knob.
- (5) Adjust the **MOD/DEPTH (16)** knob to achieve required modulation ratio.

PRECAUTION ITEMS

- (1) The **DC OFFSET (11)** knob, will provide a DC level voltage of $\pm 10V$ (no load) or $\pm 5V$ (50Ω load). However, the signal amplitude plus the DC level, is limited to $\pm 20V$ (no load) or $\pm 10V$ (50Ω load). In case of over voltage, clipping will appear as shown in Figure 6.
- (2) The main OUTPUT terminal is calibrated into a 50Ω load. This indicates that the signal source impedance is 50Ω . The OUTPUT terminal may be connected to any circuit input impedance, but output the voltage and terminal impedance will not be calibrated. To avoid oscillation, the OUTPUT terminal should be connected to a 50Ω load (especially when using high frequency and square wave output), and the connecting cable should be as short as possible.
- (3) When the DUTY knob is full counterclockwise, the ratio of positive state to negative state, should not be less than 80:20. When the DUTY knob is full clockwise, the ratio of positive state to negative state, should not be greater than 20:80. Square waves can be expanded to pulse waves, triangle waves can be expanded to ramp waves, sine waves can be expanded to unsymmetrical sine waves. The Figure 7 shows the effect of the DUTY control adjustment on different waveforms.

Figure 6

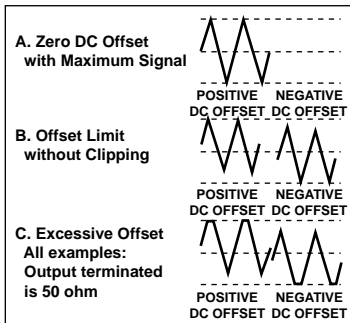
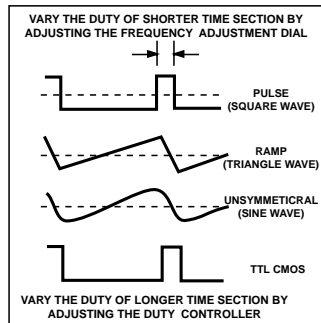

Figure 7



FUSE REPLACEMENT (See Figs. 2 and 4)

Preliminary: Disconnect test leads from circuit and Function Generator. Push Power Switch off and unplug the power cord from the rear of the Function Generator.

Warning: Failure to turn off and remove power from the Function Generator before changing the mains power fuse could result in damage to the instrument and the operator.

Fuse replacement: Remove the fuse by inserting a small flat blade screwdriver into the notch at the bottom of the mains power connector socket. Slide the fuse holder out. Replace the fuse with one of the following:

115 VAC 50/60 Hz: T0.315A/250V fuse (5mm x 20mm), I.R. 100KA – Wavetek p/n 2400-05-0069, Littell Fuse p/n 218.315, or Bussmann p/n. GDC-315mA.

230 VAC 50/60 Hz: T0.160A/250V fuse (5mm x 20mm), I.R. 100KA – Wavetek p/n 2400-05-0070, Littell Fuse p/n 218.160, or Bussmann p/n. GDC-160mA.

Warning: Use only an equivalent fuse to the one specified. Use of an incorrect fuse could result in serious injury or even death.

Reassembly: Slide the fuse holder back into the fuse cavity and reconnect the power cord.

MAINTENANCE & REPAIR

If there appears to be a malfunction during the operation of the Function Generator, the following steps should be performed in order to isolate the cause of the problem: ① Review the operating instructions for possible mistakes in operating procedure. ② Inspect and test the Test Cables for a broken or intermittent connection. ③ Inspect and test the fuse. See Fuse Replacement. Except for the replacement of the fuse, or test cables, repair of the Function Generator should be performed only by a Factory Authorized Service Center or by other qualified instrument service personnel. The front panel and case can be cleaned with a mild solution of detergent and water. Apply sparingly with a soft cloth and allow the function generator to dry completely before using. Do not use aromatic hydrocarbons or chlorinated solvents for cleaning.

in U.S.A.
 Wavetek Meterman
 1420 75th Street SW
 Everett, WA 98203
 Tel: (877) 596-2680
 Fax: (425) 446-6390

in Canada
 Wavetek Meterman
 400 Britannia Rd. E. Unit #1
 Mississauga, ON L4Z 1X9
 Tel: (905) 890-7600
 Fax: (905) 890-6866

in Europe
 Wavetek Meterman
 52 Hurricane Way
 Norwich, NR6 6JB, U.K.
 Tel: int + 44-1603-404824
 Fax: int + 44-1603-482409

SPECIFICATIONS

	FG2C	FG3C
1. Main		
Frequency Range	0.3 Hz to 3 MHz (7 Range)	0.3 Hz to 3 MHz (7 Range)
Amplitude	>10Vpp (into 50Ω load)	>10Vpp (into 50Ω load)
Impedance	50Ω ±10%	50Ω ±10%
Attenuator	-20dB ±1dB x2	-20dB ±1dB x2
DC Offset	<-5V to >+5V (into 50Ω load)	<-5V to >+5V (into 50Ω load)
Duty Cycle Control	80%:20%:80% to 1MHz Continuously variable	80%:20%:80% to 1MHz Continuously variable
LED Display	N/A	6 digits; 7.6mm (0.3 in) high
Range Accuracy	±5% +1 Hz (at 3.0 position)	N/A
2. Sine Wave		
Distortion	≤1 %, 0.3 Hz to 200 kHz THD ≤35dB below fundamental in all ranges (Specification applied from MAX. to 1/10 level)	≤1 %, 0.3 Hz to 200 kHz THD ≤35dB below fundamental in all ranges (Specification applied from MAX. to 1/10 level)
Flatness	< 0.3dB, 0.3 Hz to 300 kHz < 0.5dB, 300 kHz to 3 MHz	< 0.3dB, 0.3 Hz to 300 kHz < 0.5dB, 300 kHz to 3 MHz
3. Triangle Wave		
Linear	≥ 98 %, 0.3 Hz to 100 kHz ≥ 95 %, 100 kHz to 3 MHz	≥ 98 %, 0.3 Hz to 100 kHz ≥ 95 %, 100 kHz to 3 MHz
4. Square Wave		
Symmetry	±2%, 0.3 Hz to 100 kHz	±2%, 0.3 Hz to 100 kHz
Rise or Fall Time	≤ 100ns at maximum output. (into 50Ω load)	≤ 100ns at maximum output. (into 50Ω load)
5. CMOS Output		
Level	4Vpp ±1Vpp to 14.5Vpp ±0.5Vpp adjustable	4Vpp ±1Vpp to 14.5Vpp ±0.5Vpp adjustable
Rise or Fall Time	≤ 120ns	≤ 120ns
6. TTL Output		
Level	≥ 3Vpp	≥ 3Vpp
Fan Out	20 TTL load	20 TTL load
Rise or Fall Time	≤ 25ns	≤ 25ns
7. VCF		
Input voltage	0 to 10V ±1V(100:1)	0 to 10V ±1V(100:1)
Input Impedance	10kΩ ±10%	10kΩ ±10%
8. GCV		
Output voltage	N/A	To set the voltage between 0 to 2V as per different frequency.

FG2C**FG3C****9. Sweep Operation**

Sweep/Manual	N/A	Switch selector
Sweep/Rate	N/A	100:1 ratio max. and adjustable
Sweep/Time	N/A	0.5 Sec to 30 Sec adjustable
Sweep/Mode	N/A	Lin./Log. switch selector

10. Amplitude Modulation

Depth	N/A	0 to 100%
MODulation Frequency	N/A	400 Hz (INT), DC to 1 MHz (EXT)
Carrier BW	N/A	100 Hz to 3 MHz (-3dB)
EXT Sensitivity	N/A	≤10Vpp for 100 % modulation

11. Frequency Modulation

Deviation	N/A	0 to ±5%
Modulation Frequency	N/A	400Hz (INT), DC to 20 kHz (EXT)
EXT Sensitivity	N/A	≤10Vpp for 10% modulation

12. Frequency Counter

Int./Ext.	N/A	Switch selector
Range	N/A	0.3 Hz to 3 MHz (5 Hz to 150 MHz EXT)
Accuracy	N/A	Time base accuracy ±1count
Time base	N/A	±20ppm (23°C ±5°C) after 30 minutes warm up
Resolution	N/A	The maximum resolution is 10 nHz for 1Hz and 1 kHz for 100MHz
Input Impedance	N/A	1MΩ/150pf
Sensitivity	N/A	≤ 35mVrms (5Hz to 100MHz) ≤ 45m Vrms (100MHz to 150MHz)

13. General

LED Display	N/A	6 digits; 7.6mm (.3 in) high
Power Source	115, 230VAC ±15%, 50/60Hz	115, 230VAC ±15%, 50/60Hz
Operation Environment	Indoor use, Altitude up to 2000m. Ambient Temperature 0°C to 40°C Relative Humidity 80%(maximum). EN61010-1, Installation category II, Pollution Degree 2	
Storage Temperature & Humidity	-10 °C to 70°C @ 70% R.H.(maximum).	
Accessories	1 each RTL-1, Instruction Manual, Spare Fuse	2 each RTL-1, Instruction Manual, Spare Fuse
Dimension	243(w) x 93(H) x 292(D) mm	
Weight	Approx. 2.0 kgs.	Approx. 2.2 kgs.
Safety:	Meets EN61010-1:1993. Installation category II Pollution degree 2	



EMC: This product complies with requirements of the following European Community Directives: 89/336/EEC (Electromagnetic Compatibility) and 73/23/EEC (Low Voltage) as amended by 93/68/EEC (CE Marking). However, electrical noise or intense electromagnetic fields in the vicinity of the equipment may disturb the measurement circuit. Measuring instruments will also respond to unwanted signals that may be present within the measurement circuit. Users should exercise care and take appropriate precautions to avoid misleading results when making measurements in the presence of electronic interference.