

Lecture 3

Exercise 1: Draw the diagram of the telephone set described below.

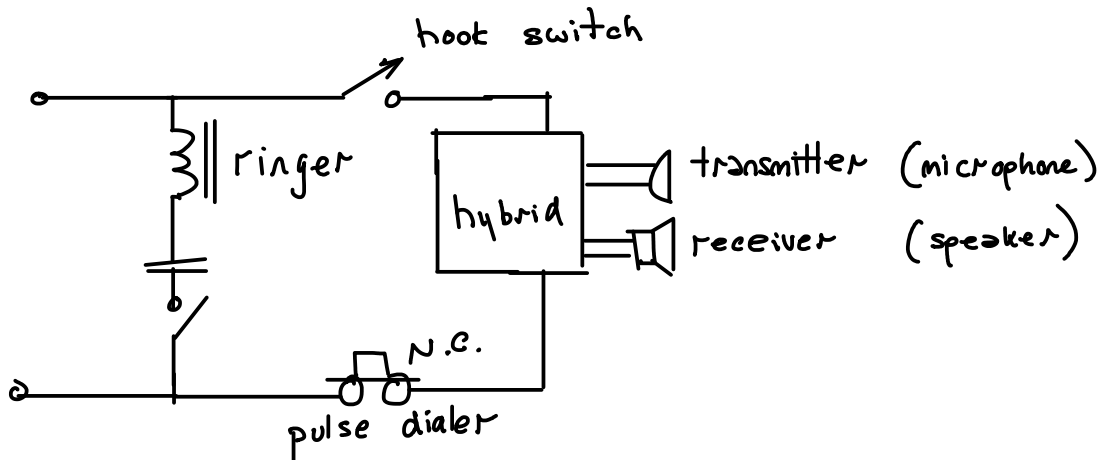

Exercise 2: Assuming a zero-length loop and CO current-limiting resistors of 400 ohms and phone resistance of 200 ohms, what is the loop current? What are the voltages relative to ground assuming the CO resistance is split into two 200 ohm resistors?

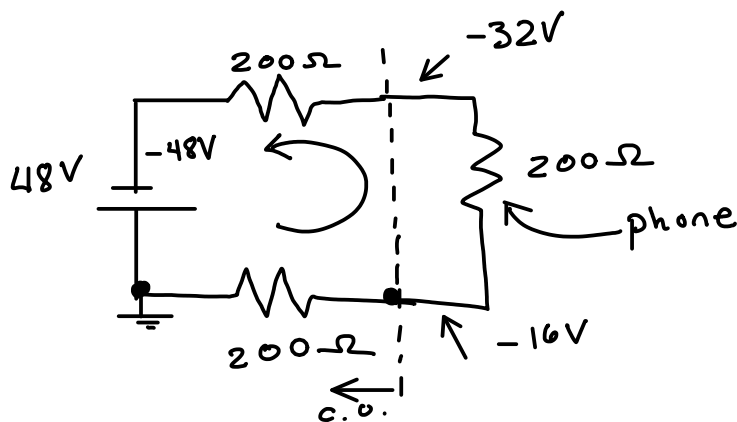

$$I = \frac{V}{R} = \frac{48}{200 + 200 + 200} = \frac{48}{600} = 80 \text{ mA}$$

voltage drop in each resistor = $80 \text{ mA} \cdot 200 \Omega = 16 \text{ V}$

Exercise 3: If the battery voltage is 48V and the loop current is $48 \mu\text{A}$, what is the loop resistance? Is the phone on-hook or off-hook? What if the loop current is 48 mA?

$$R = \frac{V}{I} = \frac{48}{48 \times 10^{-6}} = 10^6 \Omega = 1 \text{ M}\Omega \Rightarrow \text{on-hook}$$

$$= \frac{48}{48 \times 10^{-3}} = 10^3 \Omega = 1 \text{ k}\Omega \Rightarrow \text{off hook}$$

Exercise 4: Assume the CO and telephone in the above example are now operating over a 15kft (about 5km) 24-gauge loop. What is the loop current?

$$R = 52 \Omega / 1000'$$

$$R_{\text{loop}} = 15 \times 52 = 780 \Omega$$

$$I_{\text{loop}} = \frac{V}{R} = \frac{48\text{V}}{780 + 600} = 34 \text{ mA}$$

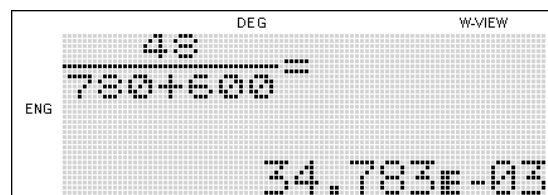

Exercise 5: What is the maximum number of DTMF digits that could be sent in the time it takes to dial a '5' and wait until the start of the next digit?

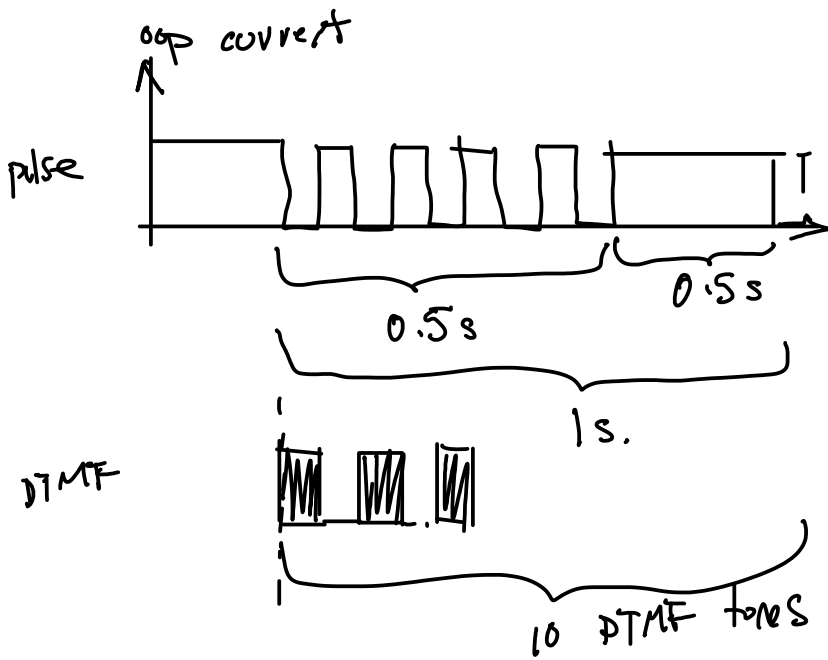

dial 5: $5 \times 0.1s +$

			A
			B
			C
*	0	#	P

Exercise 6: What is the amplitude of a -6 dBm tone?

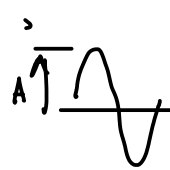

$$s(t) = A \cos \omega t$$

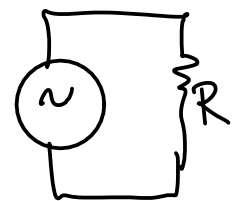

Amplitude

$$0 \text{ dBm} = 1 \text{ mW}$$

$$1 \text{ mW} \times 10^{\left(\frac{-6}{10}\right)} \approx 0.25 \text{ mW}$$

$$P = \frac{V_{\text{rms}}^2}{R}$$

$$V_{\text{rms}} = \frac{1}{\sqrt{2}} \cdot A \approx 0.707 A$$

$$P = 0.25 \times 10^{-3} = \frac{V_{\text{rms}}^2}{600}$$

$$A = \sqrt{2} \cdot V_{\text{rms}}$$

$$V_{\text{rms}} = \sqrt{600 \cdot 0.25 \times 10^{-3}}$$

$$A = \sqrt{2 \cdot 600 \cdot 0.25 \times 10^{-3}} = \sqrt{0.3} = 0.55 \text{ V}$$

