

Modulation

This lecture describes modulation, the technique used to transmit data signals over band-limited channels.

After this lecture you should be able to: explain the purpose of modulation; list some advantages of digital modulation; write expressions for the time-domain signal, draw diagrams of the modulator, and draw constellation diagrams for: OOK, ASK, 4- and 8-PSK, m -ary QAM modulation; determine the spectrum of a modulated signal from the spectrum of the modulating signal, compute the frequencies of FSK, MSK and GMSK signals, and determine if constellations are Gray-coded.

Modulation

The purpose of modulation is to shift the spectrum of the baseband signal to a higher frequency so it can pass through a bandpass channel.

For example, in AM broadcasting a baseband audio signal (0-10 kHz) is shifted to a higher frequency for example, to a carrier frequency of between about 0.6 to 1.6 MHz, so it can be transmitted by an antenna and propagate to radio receivers

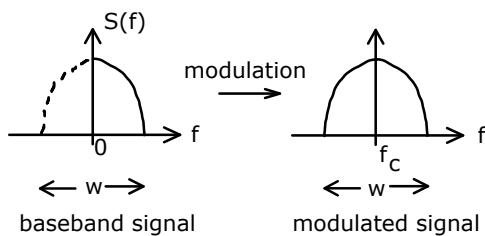

Another example is a TV video signal that is shifted to a frequency of several hundred MHz for transmission over a co-ax cable. Different channels are shifted to different frequencies. This also allows multiple TV signals to be carried on the same cable without interfering with each other (FDMA).

The circuit or function that generates the modulated signal is called a modulator. The corresponding reverse operation at the receiver is called demodulator. Often both functions are included in one piece of equipment called a “modem” (for MODulator-DEModulator)

Analog vs Digital Modulation

Analog modulation modulates the carrier with an analog baseband signal. The receiver recovers the analog signal. Examples are AM and FM audio broadcasting.

Digital modulation modulates the carrier with a digital baseband signal. The receiver recovers the digital data (bits). Almost all communication systems have switched to digital modulation (cellular, TV, ...). There are many advantages to digital modulation including:

- better spectral efficiency (less spectrum required)
- better power efficiency (less transmit power required)
- the ability to transmit any type of content (audio, video, data, etc).

We will study only digital modulation in this course.

PSK and QAM Modulation

There are dozens of different types of modulation. We will only look at some of the simplest and most common examples.

The simplest type of modulator simply multiplies a sinusoidal carrier with the baseband signal.

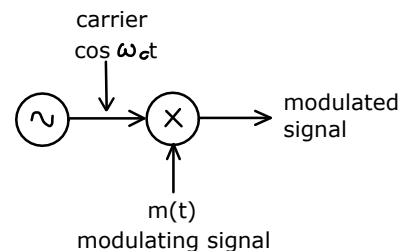

The modulated signal is

$$s(t) = m(t) \cos(\omega_c t)$$

where the carrier is $\cos(\omega_c t)$ where $\omega_c = 2\pi f_c$ is the (angular) frequency of the carrier signal and $m(t)$ is the modulating signal.

If the baseband signal has values 0 and 1 then the modulation is called on-off-keying (OOK) or Amplitude Shift Keying (ASK). This is used only for the very simplest applications (e.g. remote controls).

Exercise 1: Draw the waveform of an OOK (ASK) signal. Show the periods of the carrier and the symbol period of the modulating signal.

QAM

If the baseband signal has values ± 1 then the modulation inverts the polarity of the signal. This is equivalent to shifting the phase of the signal by 180 degrees since:

$$\cos(\theta + \pi) = -\cos(\theta)$$

For this reason this type of modulation is usually called BPSK (Binary Phase Shift Keying).

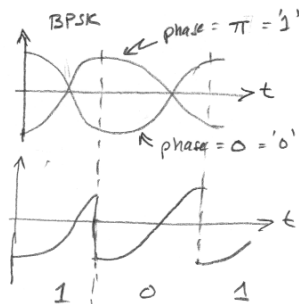

We can also vary the phase of the signal by other amounts. For example, we can use phase shifts of 0, 90, 180 and 270 degrees to transmit 4 different phases.

The transmitter can encode 2 bits if there are four possible phases. This type of modulation is called QPSK (Quadrature PSK).

This type of modulator can be implemented as two signals modulating two carriers that are orthogonal (90 degree phase difference). One is called the in-phase (I) component and the other is called the quadrature (Q) component.

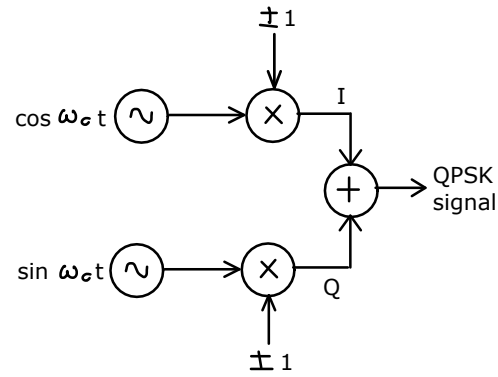

The equation for the modulated signal is:

$$s(t) = \pm 1 \cos(\omega_c t) + \pm 1 \sin(\omega_c t)$$

It is common to view the modulating signal as a complex value modulating (multiplying) a single carrier. For the case of QPSK this complex modulating signal has values e^{j0} , $e^{j\pi/2}$, $e^{j\pi}$, $e^{j3\pi/2}$.

We can draw the possible I and Q amplitudes on a 2-D plane. This is called a constellation diagram. It is a phasor diagram showing the carrier magnitude and phase of each for each possible modulation value.

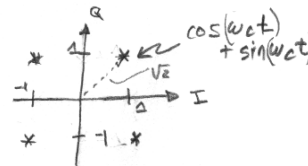

Exercise 2: Label the other three points in the constellation diagram with the equation of the signal that corresponds to that point.

Instead of just changing the phase of the carrier, we can change the amplitudes of the I and Q components. For example if we multiply the I and Q components by +/-1 or +/-3 (total of 4 levels) we can transmit 16 different possible waveforms (4 different I amplitudes and 4 different Q amplitudes). This allows us to transmit 4 bits per symbol. This is called 16-QAM. This is the constellation:

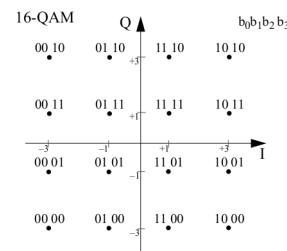

where each point is labelled with the bits that are transmitted if that symbol (a carrier with the given I and Q amplitudes) is transmitted.

However we can transmit twice as much data: the real and imaginary components can be modulated independently.

M-ary Modulation

In general if we can transmit M distinct signals (symbols) we can encode $\log_2(M)$ bits. This is called M -ary modulation. For example 64 – QAM can encode 6 bits per symbol using a 64-point (8×8) constellation. The following diagram shows the 64-QAM constellation used for the 802.11 WLAN standard:

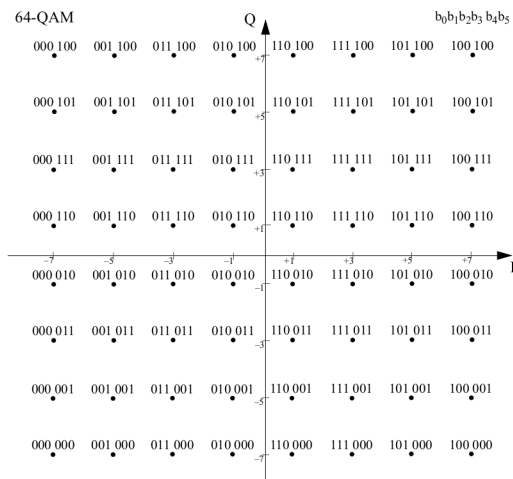

The constellation points can also be arranged in a circle. This corresponds to changing only the phase of the signal while leaving the amplitude fixed. We can, for example have 8 phases (called 8-PSK) and transmit 3 bits per symbol.

Exercise 3: Draw the constellation for 8-PSK.

Demodulation of QAM

By multiplying the received signal by I and Q carriers and low-pass filtering we can recover the transmitted I and Q components.

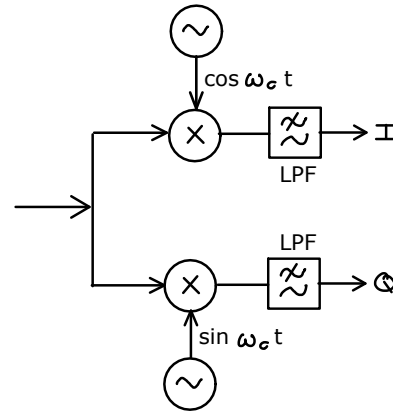

The receiver has to recover the phase of the carrier to accurately set the I and Q phases. This can be done, for example, by transmitting a preamble that has a known phase.

FSK, MSK, GMSK

We can also vary the frequency of the signal. This type of modulation is called Frequency Shift Keying (FSK). It cannot be represented on a phasor diagram because the carrier phase is constantly changing (it would be an arc on a circle).

Typically there are only two frequencies. The frequency deviation is the difference between the two frequencies. The bandwidth of the FSK signal increases with increasing frequency deviation and also with increasing frequency of the modulating signal.

A variant of FSK where the frequency shift is equal to half of the bit rate is called minimum shift keying (MSK). For example, if the symbol rate was 1kHz the two frequencies would differ by 500Hz. This makes the two signals orthogonal and simplifies the design of the receiver.

A variant of MSK where the modulating signal is filtered by a filter with a Gaussian impulse response

Spectra of Modulated Signals

Multiplying the the baseband signal by a carrier shifts the spectrum of the modulating signal from zero (DC) to the carrier frequency. Instead of being centered at zero the spectrum of the modulating signal is now centered around the carrier frequency.

The bandwidth of the modulated signal is double the baseband bandwidth because the negative portion of the spectrum is also shifted to the carrier frequency.

is called GMSK (Gaussian MSK). The advantage of GMSK is that it has a low sidelobe levels so it is often used for channelized RF systems such as GSM (2G cellular) and DECT (European digital cordless phone).

Gray Coding

Constellations are usually *gray coded*. This means that the bits corresponding to adjacent points in the constellation differ by only one bit. Since errors between adjacent points are the most likely, gray coding minimizes the bit error rate. The 16-QAM and 64-QAM constellations shown above are gray-coded.

Exercise 4: Assign gray-coded values to the 8-PSK constellation.