

Analysis of Wireless CSMA/CA Network Using Single Station Superposition (SSS)

Tamer M.S. Khattab, Mahmoud T. El-Hadidi and Hebat-Allah M. Mourad

Abstract In this paper we introduce an analytical model to calculate the performance of the wireless LAN MAC protocol – known as Carrier Sense Multiple Access with Collision Avoidance (CSMA/CA) – taking into consideration the random exponential back off algorithm. The effects of changing the arrival rates and the number of users on normalized throughput and packet delay are demonstrated. Furthermore, the effects of varying the back-off algorithm parameters – such as the number of retrials on a packet transmission before discarding it – on the throughput and delay are investigated.

Keywords Wireless Networks, LAN, Protocol analysis, Performance evaluation, Single station superposition, Multiple access

1. Introduction

Mobility in computing and communications has recently become more and more essential, especially for business usage. The suitable transmission technique for mobile applications is wireless communication.

Notebook computer is a vivid example of mobile computers. It has led to the evolution of Wireless Computer Networks of which Wireless Local Area Networks are one kind.

Wireless LAN can be categorized by its MAC protocol. One of the major protocols used for wireless LAN is the Carrier Sense Multiple Access with Collision Avoidance (CSMA/CA), which is a variation of CSMA/CD used for Ethernet. The problem with CSMA/CD is that bandwidth efficient collision detection in radio channels is difficult to achieve. This inefficiency is a result of the high dynamic attenuation of radio signals. This high attenuation makes it practically very difficult for a radio transceiver to listen to other signals while transmitting, which is essential for the collision detection part of CSMA/CD. To be able to overcome this problem and still achieve an acceptable performance, the collision detection is replaced by collision avoidance [1].

CSMA/CA is used for IEEE 802.11 distributed access and has been adopted in many products existing in the market, such as the WaveLAN RF Wireless LAN of AT&T [2]. Due to its importance, this protocol is reviewed

in some details in this paper. The protocol differs from the CSMA/CD in two ways, the first is that it doesn't contain a collision detection algorithm, and the second is that it defers the transmission for a random exponential backoff in case of medium busy. Hence, models for CSMA/CD cannot be directly applied to this protocol and a model needs to be established from scratch. The work done on the protocol till now either used simulation or ignored the back-off feature of the protocol to get to a mathematical model [3, 4].

In this paper, a Markov model for one station is established taking the effect of other stations into account using some global state-dependent variables. Mathematical representation of performance in terms of throughput and delay is obtained by solving this model at equilibrium using a technique called Single Station Superposition (SSS) to obtain the overall values of the performance parameters for a finite number of nodes.

The organization of the paper is as follows: section 2 introduces the network architecture and protocol. Section 3 presents the used network models and describes the main parameters and assumptions. In section 4, the mathematical expressions for network throughput and delay are derived and expressed in terms of the probabilities of busy and collisions. Section 5 details the analysis leading to expressions for these two probabilities. In section 6 numerical results are obtained under different conditions and commented. Concluding remarks are given in section 7.

2. Network architecture and MAC protocol for CSMA/CA

Fig. 1 shows the network architecture for the CSMA/CA scheme. Clearly it is of the ad-hoc type, with connections established directly between stations (i.e. on a peer-to-peer basis).

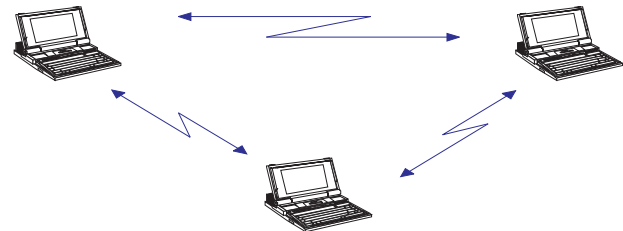

Fig. 1. CSMA/CA network architecture.

Received October 12, 2000. Revised January 30, 2001.

T.M.S. Khattab et al., Electronics and Communication Department,
Faculty of Engineering, Cairo University, Giza, Egypt
E-mail: tamer.khattab@alcatel.com
Correspondence to T.M.S. Khattab.

In practice, the protocol uses only one frequency, and single-spreading code is utilized by all stations for transmission from one node to the other. Thus, only one station can successfully transmit in the network at any time. The operation of the CSMA/CA MAC protocol can be described in terms of the state transition diagram shown in Fig. 2.

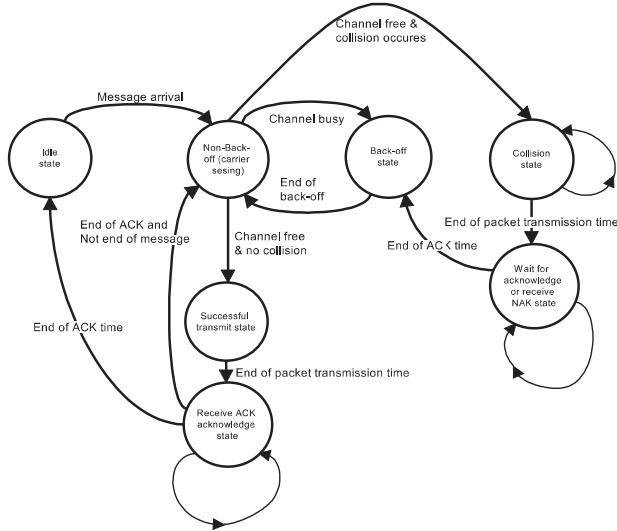

Fig. 2. State transition diagram for CSMA/CA.

Initially, each station is in the idle state. When a new message¹ arrives, it is stored in a transmit buffer and the station moves to a non-backoff carrier sensing state. Depending on whether the channel is busy or not busy, the station moves either to a backoff state or a transmit state, respectively. When in the backoff state, a random time – uniformly chosen from a progressively increasing interval – is used for backoff. So long as the station is in the back-off state, it continues to sense the channel and decrements the backoff time only when the channel is free. When the backoff time decreases to zero, the station moves from the backoff state to the non-backoff state. On the other hand, when a station is in the transmit state two possibilities exist: either transmission is done successfully (as indicated by the reception of an ACK signal), or transmission is not successful due to collision with transmissions from other station(s) (as indicated by the absence of ACK or the reception of NAK). In the first case, the station moves to the ACK state while in the second case the station moves to the collision state. When in the collision state, the back-off interval is increased, a new backoff time is selected, and the station moves to the backoff state. On the other hand, a station in the ACK state, may either returns to the non-back-off carrier sensing state (if more units of the original message are to be transmitted), or else returns to the idle state (in case the message transmission is completed).

¹ A message is a collection of data that are related together and might be divided into a group of packets that are sent one after the other.

The above algorithm for the CSMA/CA can be readily represented in the form of a flowchart as shown in Fig. 3. In this figure, NAV is the Network Allocation Value and denotes the width of the interval from which a uniformly distributed backoff period (BOF) is selected. In case of collision, NAV is increased using binary exponential backoff ($NAV = 2^i \cdot CW_{min}$), where CW_{min} is the minimum backoff window, which is the size of NAV when ($i=0$). In practice this increase is stopped when “ i ” reaches an upper value.

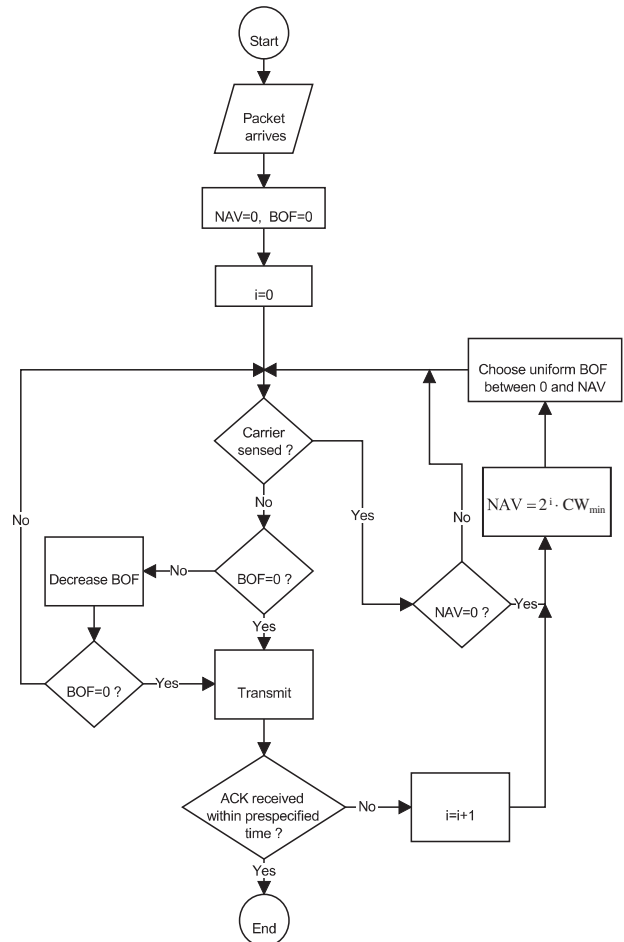

Fig. 3. Flow chart of CSMA/CA MAC procedure.

3. Network models

We next consider the modelling of a network consisting of U stations that employ the CSMA/CA MAC protocol. At an arbitrary time instant one may assume N_I stations to be idle and the remaining $U - N_I$ stations to be active. Based on the outcome of channel sensing, and depending on whether the backoff timer has decreased to zero or not, an active station may be successfully transmitting, in backoff state, or in collision state. Thus among the $U - N_I$

active stations, S will be successfully transmitting, B will be in back-off and C will be in collisions. Fig. 4 depicts a schematic representation of a network whose stations belong to one of the above states. The figure also indicates the logic that determines the conditions under which a station is successfully transmitting (switch is on), as well as the interaction between a station and the channel (feedback link for channel state).

Though Fig. 4 can be the basis for a network queuing model which would be solved in principle to deduce system performance parameters, exact solution is rather intractable. To see this, assume that the state X_j of an individual station can be either idle (I), successfully transmitting (S), backed off (B), or in collision (C). That is for any time t :

$$\begin{aligned} X_j(t) &= I & w.p. & P_I \\ &= S & w.p. & P_S \\ &= B & w.p. & P_B \\ &= C & w.p. & P_C \end{aligned}$$

Clearly, station j moves from state $X_j(t)$ at t to state $X_j(t + \Delta t)$ at $t + \Delta t$ depending on:

$X_j(t), X_k(t)$ where $k = 1, \dots, U$ and $k \neq j$, arrival rate of new messages for each station, service rate of on-going message, and $X_k(t + \Delta t)$.

Since each station can be in any one of four possible states (I, S, B, C), the network in Fig. 4 represents a Markov queueing model of dimension $[4 \times 4(U - 1) \times$

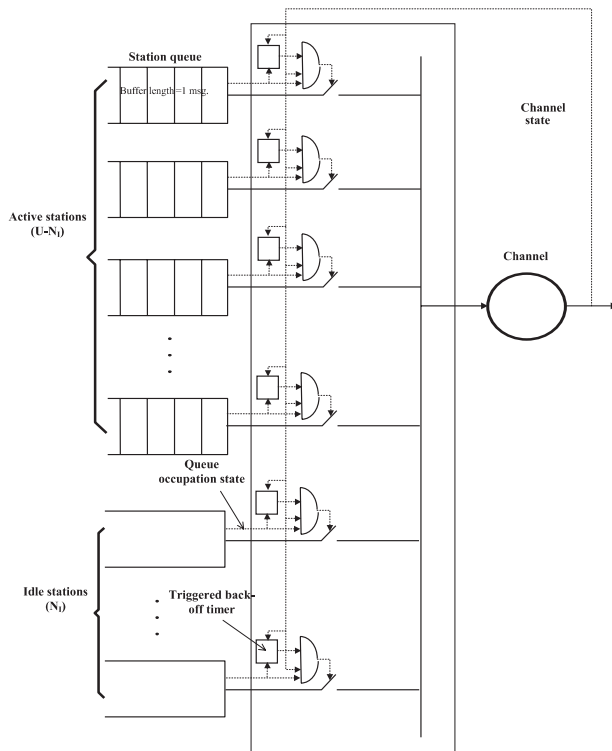

Fig. 4. Schematic representation of a network queuing model based on CSMA/CA for channel access.

$4(U - 1)$. Obviously, the number of state equations is $O(U^2)$. To reduce the complexity of this problem we propose to use the so called Single Station Superposition (SSS) approach [5], which is more general and readily understandable than the so called Equilibrium Point Analysis (EPA) of [6]. Using the SSS approach, we use a Markov model to represent a single station, and lump the effect of all other stations on that station using global parameters (such as the probability of channel being busy, and the probability of collision). The equilibrium state probabilities for the single station can then be deduced in terms of the global parameters. Next, we derive relationships for the global parameters in terms of the single station state probabilities. Finally, we deduce the performance parameters for the entire network by the proper superpositions of the same parameter for all nodes in the network. Details for the mathematical analysis are given in section 4. In the following we shall present the Markov model used in the SSS approach.

Model Assumptions

- Time axis is slotted with time slot equal to τ .
- Total number of stations is U .
- Idle stations generate messages with probability λ per slot, per user.
- Active stations do not generate traffic until they become idle.
- Message length has geometrical distribution with mean equal to T_{av} slots. Hence, the probability of reaching message end after transmitting a certain number of packets is taken to be σ , where $\sigma = \frac{1}{T_{av}/L}$, and L is the fixed packet length. This also means that a message consists of $1/\sigma$ packets on the average.
- Each station can have at most one message waiting for transmission. (Hence stations buffer is equal to one message).
- A station that senses the channel finds it busy with probability b .
- A station transmitting for the first time that finds the channel busy decides to wait for a random duration in the range $[0, V_i - 1]$ free channel slots, with uniformly distributed probability before trying transmission again.
- A station coming from collision state waits for a random back-off time in the range $[0, V_i - 1]$ free channel slots with uniformly distributed probability density function before attempting transmission again, where i is the number of transmission retrials.
- Collision is detected by the station receiver and is informed to the transmitter through acknowledgment.
- Acknowledgment transmission time is 3 time slots.
- Collision occurs with probability f .
- Packet length is constant and is assumed to be equal to L time slots.
- The effects of channel errors are assumed to be independent of stations' state. It is taken into account by introducing a parameter called probability of no-error.
- Time slot is very small compared to both the packet transmission time and the mean time between arrival of messages.

- All stations have identical distributions.
- Each station is capable of switching between sensing and transmitting within one time slot.
- The effect of hidden terminal problems and captures are not considered.

Model State Transition Diagram

Based on the above assumptions, and referring to Fig. 2, one can deduce the state transition diagram for the SSS model, depicted in Fig. 5. In this figure as well as in the following text the following notations are going to be used:

I = Idle

A = Active (Queue > 0, non back-off)

C = Collision

B = Back-off

K = Acknowledgment

S = Transmitting successfully

b = Prob. {channel busy}

f = Prob. {collision}

r_{ij} = Prob. Station attempts transmission
when back-off state is B_{ij} .

$V_i - 1$ = Maximum back-off period at trial no. i

m = Maximum number of retrials before discard

L = packet length

From this figure it is clear that a station in the idle state I will receive new messages at a rate λ . With the arrival of a new message, the station immediately moves to the active state A , during the same time slot. Then it either finds the channel busy with probability b , or finds it free with probability $1 - b$. In case of a busy channel, the station goes into a back-off state, in which a random delay B_{ij} is chosen from the interval $[0, V_i - 1]$, where i is the number of transmission retries, $1 < i < m$. $V_i - 1$ is the maximum backoff period at trial i measured in units of free time slots and m is the maximum number of retrials on a packet before discarding it. To allow for the fact that after the elapse of B_{ij} free time slots the station can attempt transmitting, the model uses r_{ij} to denote the probability of such event. When a station at state A or state B_{ij} finds the channel free and decides to transmit, two scenarios are possible. The first is a successful transmission scenario in which no other station attempts to transmit (an event with probability $(1 - f)$), and in this case the station goes through states $S_1, \dots, S_L, K_1, \dots, K_3$. At the end of successful transmission, the station either becomes idle I with probability σ (this corresponds to end of message) or moves to active state A with probability $1 - \sigma$ (which implies more packets are yet to be transmitted). The second scenario of the same message is that of collision, which happens with probability f . In this case more than one station attempts transmission simultaneously. Because there is no collision detection, the collision duration extends over L time slots followed by 3 time slots for acknowledgement

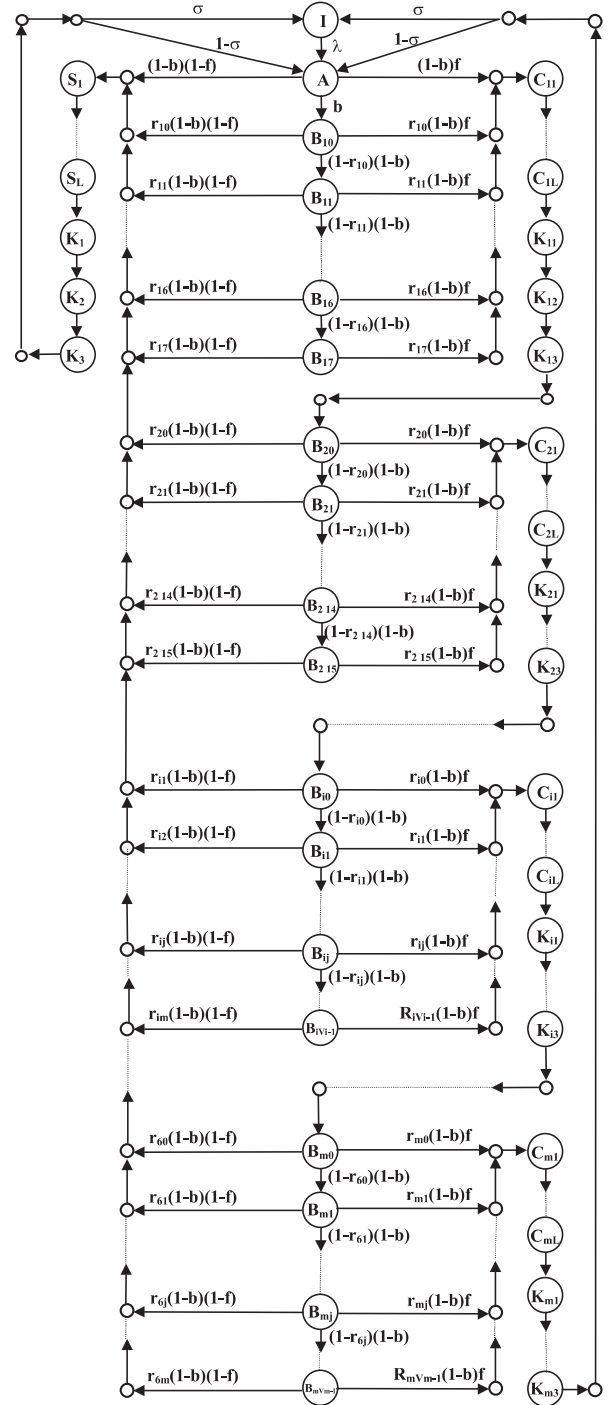

Fig. 5. State transition diagram for SSS model of the CSMA/CA MAC protocol.

(C_{i1}, \dots, C_{iL}), (K_{i1}, \dots, K_{i3}). At the end of the collision scenario, the station moves to the start of the next back-off state, in which the procedure is repeated except for the fact that i is now incremented to $i + 1$. On the other hand if the collision procedure is repeated m times for the same packet i.e. i reaches the value m without successful transmission, the backoff is reset and the node moves to the

next packet in the message (if any is remaining). This is represented by moving into state A with probability $1 - \sigma$. Alternatively, if this packet was the last packet in the message (an event that has a probability σ) the node moves into state I .

It is to be noted that in Fig. 5, a station at state B_{ij} stays in the same state so long as the channel is busy, i.e. with probability b . Also, the number of back-off states is V_i , where $V_i = 2^i \cdot CW_{\min}$ – for random binary back-off – and CW_{\min} is the minimum back-off window and is equal to 8 for standard CSMA/CA. Another important fact is that the states B_{i0} correspond to the case where a station in back-off would transmit as soon as the channel is free.

Clearly, the values of the probabilities r_{ij} at which station at state B_{ij} would transmit should be calculated for the above model to be completed.

Since the actual random backoff operation would correspond (for the case of $i = 2$) to Fig. 6(a) – and not to Fig. 6(b) which is used in deducing Fig. 5 – we calculate the values of r_{ij} based on the equivalence between Fig. 6(a) and Fig. 6(b).

4. Mathematical analysis

The solution steps for SSS are shown in Fig. 7. The equilibrium equations for the model in Fig. 5 are based on the law of flow conservation. In the following we will apply this law to the steady state probabilities for one station only then extend the results to the case of U stations. This is the so called Single Station Superposition (SSS) technique. Using the label of the state to represent the probability of being in the state, the equilibrium equations

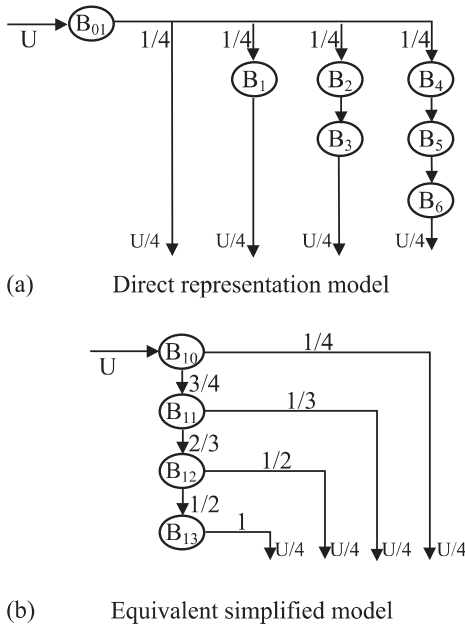

Fig. 6. Actual and equivalent models for the random back-off procedure.

are as follows:

$$B_{ij} (1 - r_{ij}) = B_{ij+1}, \quad 1 \leq i \leq m, \quad 0 \leq j \leq V_i - 2 \quad (1)$$

$$(1 - \sigma)K_{m3} + \lambda \cdot I + (1 - \sigma)K_3 = A \quad (2)$$

$$\sigma \cdot K_3 + \sigma \cdot K_{m3} = \lambda \cdot I \quad (3)$$

$$K_{i3} = (1 - b)B_{i+10}, \quad 1 \leq i \leq m - 1 \quad (4)$$

$$(1 - b)(1 - f) \left[A + \sum_{i=1}^m \sum_{j=0}^{V_i-1} r_{ij} \cdot B_{ij} \right] = S_1 \quad (5)$$

$$(1 - b)f \left[A + \sum_{j=0}^{V_1-1} r_{1j} \cdot B_{1j} \right] = C_{11} \quad (6)$$

$$(1 - b)f \sum_{j=0}^{V_i-1} r_{ij} \cdot B_{ij} = C_{i1}, \quad 2 \leq i \leq m \quad (7)$$

$$S_1 = S_2 = \dots = S_i = \dots = S_{L-1} = K_1 = K_2 = K_3 \quad (8)$$

$$C_{i1} = C_{i2} = C_{ij} = \dots = C_{iL-1} = K_{i1} = K_{i2} = K_{i3}, \quad 1 \leq i \leq m \quad (9)$$

The equilibrium equation at B_{10} will be linearly dependent on all the others; hence it is replaced by the normalizing equation which states that the sum of probabilities of all states is equal to one. This yields:

$$I + A + \sum_{i=1}^m \sum_{j=0}^{V_i-1} B_{ij} + \sum_{i=1}^L S_i + \sum_{i=1}^3 K_i + \sum_{i=1}^m \left[\sum_{j=1}^L C_{ij} + \sum_{j=1}^3 K_{ij} \right] = 1 \quad (10)$$

The normalized throughput γ can be expressed as:

$$\gamma = U \cdot P_s \quad (11)$$

where

$$P_s = \sum_{i=1}^L S_i \quad (12)$$

and P_s is the probability of being in a successful transmission state for a station.

The delay can be easily expressed as:

$$D = D_{norm} \cdot L \quad (13)$$

$$= \frac{1 - I}{P_s} \cdot L \quad (14)$$

After some mathematical manipulations, one can arrive at the following expressions:

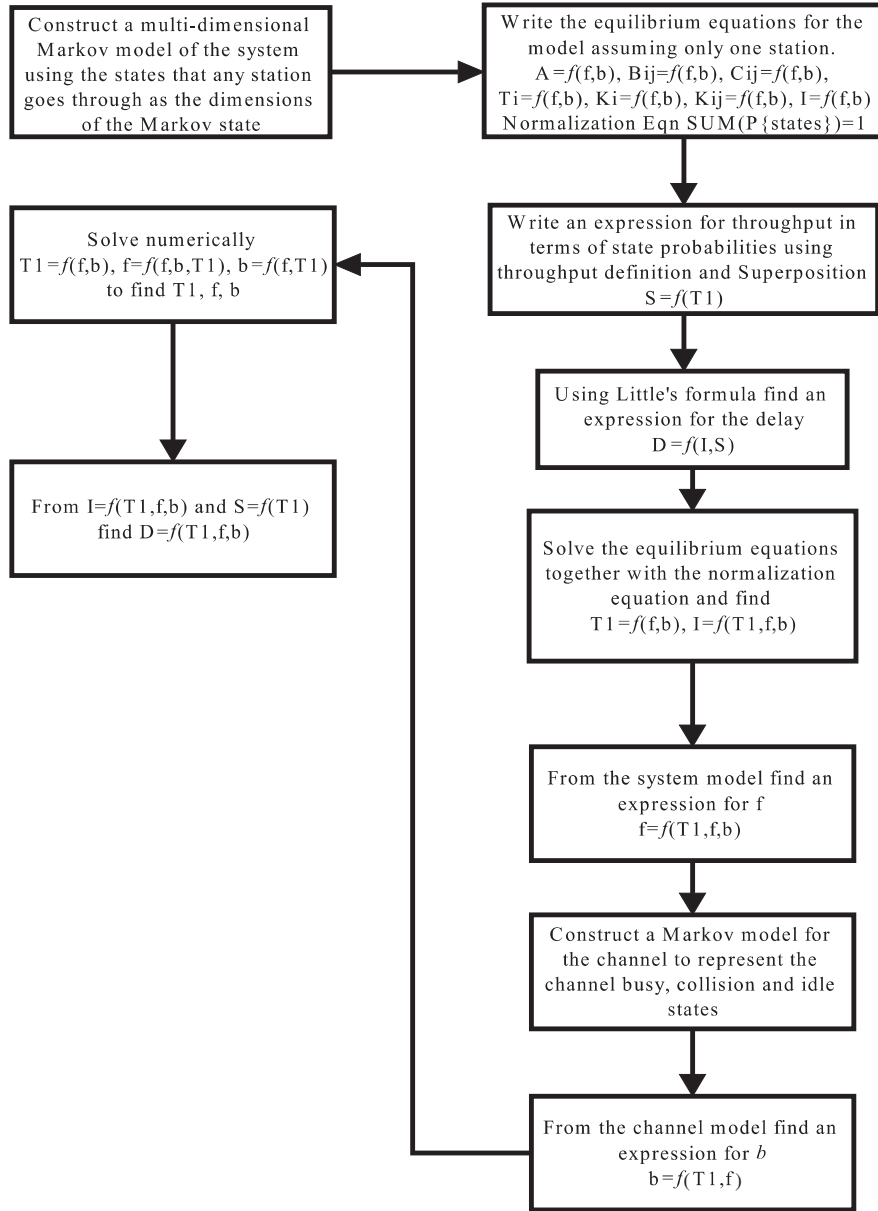

Fig. 7. Flow chart of SSS solution method.

$$S_1 = \frac{1}{\frac{\sigma}{\lambda} + (L + 3) + \frac{1}{(1-b)(1-f^m)} \left[\begin{array}{l} 1 + \frac{2CW_{min}-1}{2} \cdot b + \frac{\sigma}{\lambda} f^m (1-b) \\ + f \left(\frac{2CW_{min}-2CW_{min}(2f)^{m-1}}{1-2f} \right) \\ + f \left(\frac{1-f^{m-1}}{2-2f} \right) \\ + f(L+3)(1-b) \left(\frac{1-f^m}{1-f} \right) \end{array} \right]} \quad (15)$$

$$\gamma = U \cdot L \cdot S_1 \quad (16)$$

$$D = \frac{1 - \frac{\sigma}{\lambda} S_1 \left(1 + \frac{f^m}{1-f^m} \right)}{S_1} \quad (17)$$

Another expression to be used later is that of the normalized fresh offered load, given by:

$$G = U \cdot L \cdot \frac{\lambda}{\sigma} \quad (18)$$

The only step left to evaluate the system performance is to find expressions for f and b . These expressions will be used to get the value of S_1 in terms of system parameters. Having found S_1 in terms of the system parameters both throughput γ and delay D can be evaluated.

5. Calculating the probabilities of busy (b) and collision (f)

For U stations in the network, the probability of collision f is the probability that one or more of the other $U - 1$ nodes transmits at the time the current station is transmitting. This happens only if one of the other $U - 1$ stations is ending its back-off or transmitting for the first time at the same time as the current station. Accordingly, it can be easily deduced that:

$$f = 1 - \left(1 - \frac{S_1}{(1-b)(1-f)}\right)^{U-1} \quad (19)$$

Next we find the probability b that the medium is busy. To do so we construct a Markov queuing model as shown in Fig. 8 that represents the different states of the channels (as seen by an observing station). These states are empty E , occupied with successful transmission O_i , or occupied with collision N_i . The channel is empty when there is no node transmitting at all. It becomes occupied when one or more of the $U - 1$ remaining nodes is transmitting. If only one node is transmitting, the channel goes to states O_i with probability q . In this case it is seen by the observing station as being busy and carrying a successful transmission. This continues for the L slots period of the packet plus the 3 slots period of the acknowledgment. On the other hand, if more than one node is transmitting, the channel goes to states N_i with probability p , in which case it is seen as being in collision. It must be noted however that an observing station does not take any action towards this collision, and it is detected by the transmitting station by means of NACK or no ACK at all.

What is required here is to find the probability of finding the medium free at the sensing time. This probability is denoted by $1 - b$ and is equal to the steady state probability of having the channel at state E of the Markov model given in Fig. 8. To find this probability, the steady state equations of the above queuing models must be solved.

Solving these equations one obtains [7]:

$$1 - b = \frac{1}{1 + (L + 3)(q + p)} \quad (20)$$

From the previous description q is the probability of only one station of the $U - 1$ stations being transmitting.

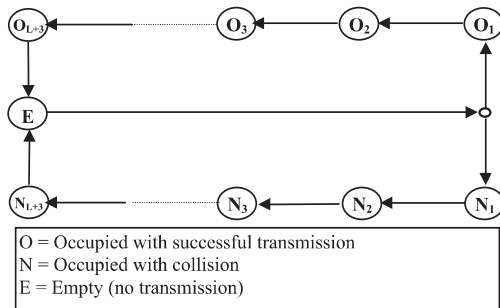

Fig. 8. Markov state model of the channel.

Hence:

$$q = (U - 1)(L + 3)S_1 \quad (21)$$

On the other hand, p is the probability of two or more stations transmitting at the same time on the channel. This is given by:

$$p = 1 - (U - 1)(L + 3)S_1 - \left[1 - (L + 3)S_1 - (L + 3)\left(\frac{f}{1-f}\right)S_1\right]^{U-1} \quad (22)$$

From equations (20), (21), and (22) it can be shown that:

$$b = 1 - \frac{1}{1 + (L + 3)\left(1 - \left[1 - (L + 3)S_1 - (L + 3)\left(\frac{f}{1-f}\right)S_1\right]^{U-1}\right)} \quad (23)$$

Equations (15), (19), and (23) are three non-linear equations in three variables S_1 , f , and b . Assuming that all the system parameters like arrival rate λ and number of users U are known, these equations can be solved together numerically to get numerical values for S_1 , f , and b . These values can be used in the throughput equation (16) and the delay equation (17) to obtain numerical results for the performance of the CSMA/CA protocol.

6. Numerical results

The results are obtained assuming $\sigma = 1$ which means that on the average a message contains only one packet, and also the time slot $\tau = 3 \mu\text{s}$. Fig. 9 depicts a comparison between the normalized throughput against the normalized

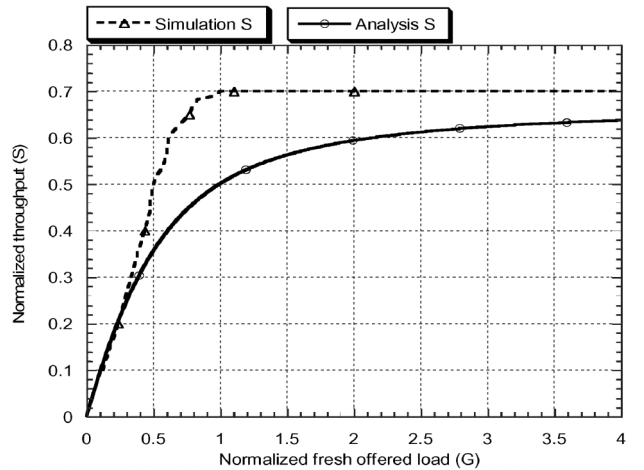

Fig. 9. Normalized throughput S from analysis and simulation against normalized fresh offered load G for $L = 100$ slots and $U = 2$.

fresh offered load for both our analysis and the simulation done in [3]. The observed deviation is a result of considering the use of inter-frame space in the simulation model, which enhances the system throughput as seen in the simulation results.

In Fig. 10 we have changed the value of probability of arrival λ and calculated the corresponding throughput. It is noticed that the throughput increases with the increase in the arrival rate. This is expected since higher λ means that more slots of the channel capacity are used. The increase continues till it reaches a maximum value, which depends on the number of users in the system. Again, this behavior is expected since as the number of users increases one expects more collisions to take place among them. This fact is illustrated using the plots in Fig. 14 which shows the effect λ and U on the probability of collision f . On the other hand, one can notice from Fig. 10 that the maximum throughput decreases as the number of stations increases. This can be explained in view of discarding of colliding packets after a certain number of retries. To study this phenomena in more details, Fig. 16 is given. In this figure we notice that as the number of retries before discarding m increases, the steady state value and the maximum

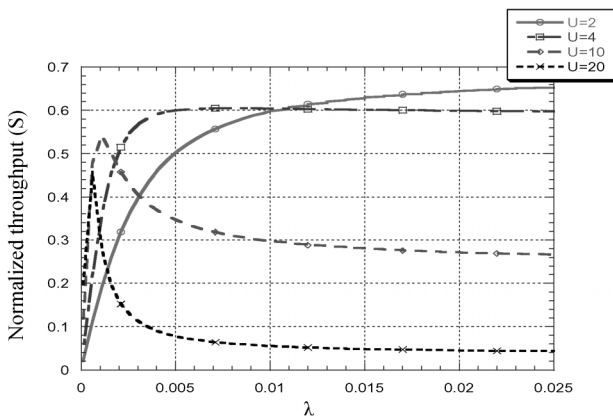

Fig. 10. Normalized throughput S as a function of probability of arrival λ for different values of U and for $m = 2$, and $L = 100$ slots.

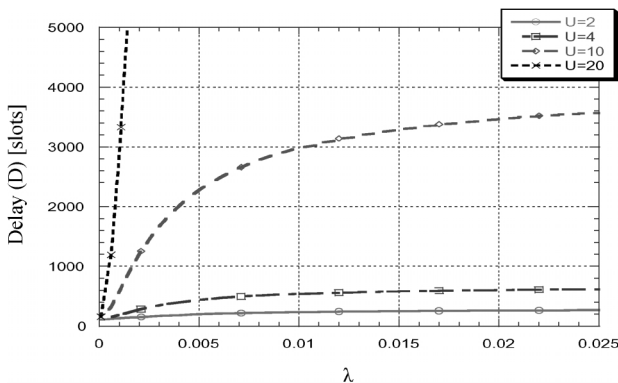

Fig. 11. Delay D in slots as a function of probability of arrival λ for different values of U and for $m = 2$, and $L = 100$ slots.

value of the throughput for different number of stations are approaching each other. In fact not only they approach each other but they reach higher values.

This behavior can be explained in view of the fact that as the number of retries increases the probability of discarding a message decreases and hence the throughput increases. This increase in the throughput is more significant at higher number of users, as the probability of collision is higher. This is why the two curves for maximum throughput and steady state throughput approach each other.

In Fig. 11 we have plotted normalized delay D as a function of λ and U . One observes that the delay reaches a saturation value with increasing the probability of arrival. This saturation behavior is a result of the consideration of finite number of retries on colliding packets, which gives a bounded delay. On the other hand, it is also noticed that increasing number of users always increases the delay regardless of the value of the probability of ar-

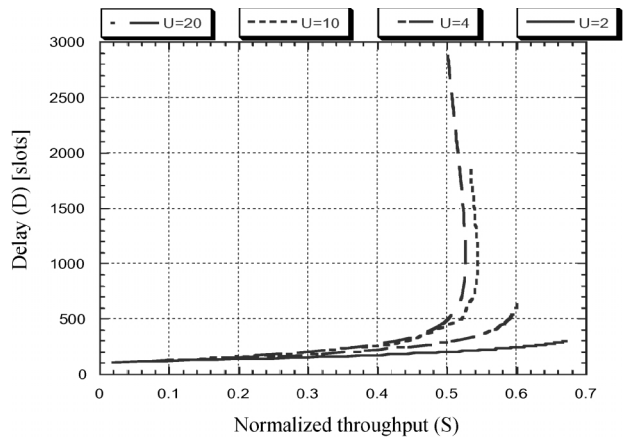

Fig. 12. Delay D in slots against throughput S for different values of U and for $m = 8$, $L = 100$ slots.

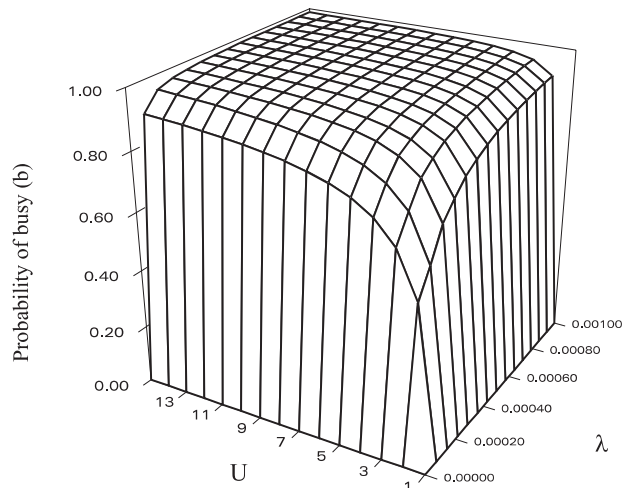

Fig. 13. Probability of channel sensed busy b as a function of U and λ for $L = 100$ slots and $m = 2$.

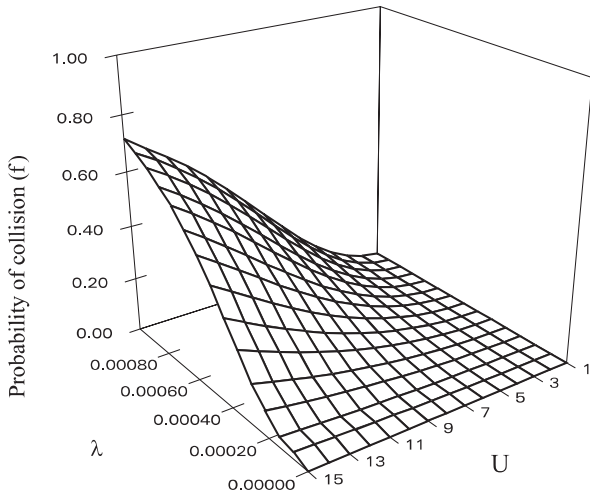

Fig. 14. Probability of collision f as a function of U and λ for $L = 100$ slots and $m = 2$.

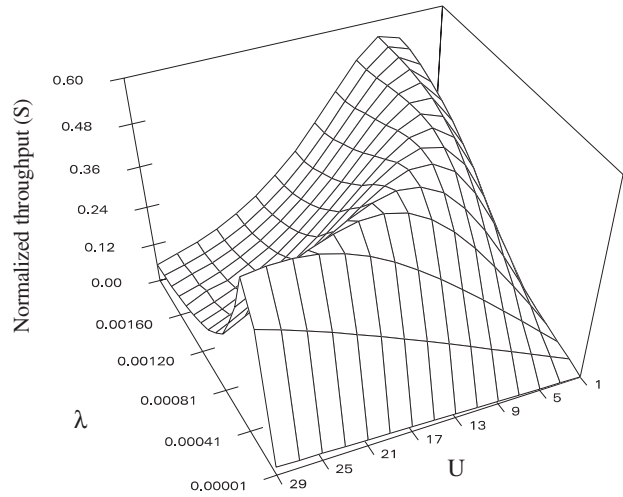

Fig. 15. Normalized throughput S as a function of U and λ for $L = 100$ slots and $m = 2$.

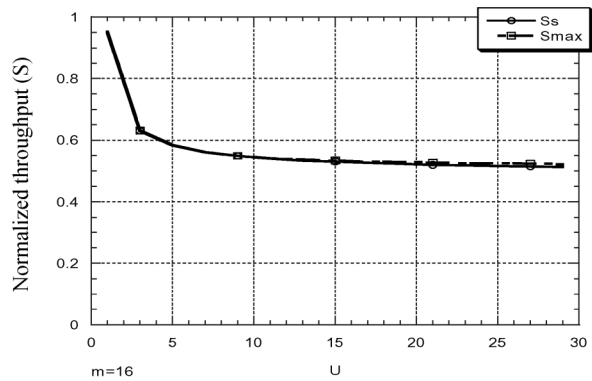
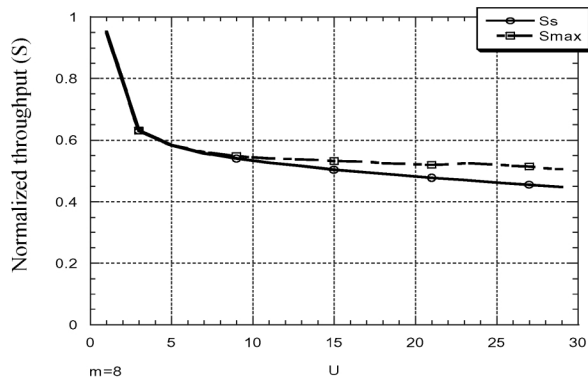
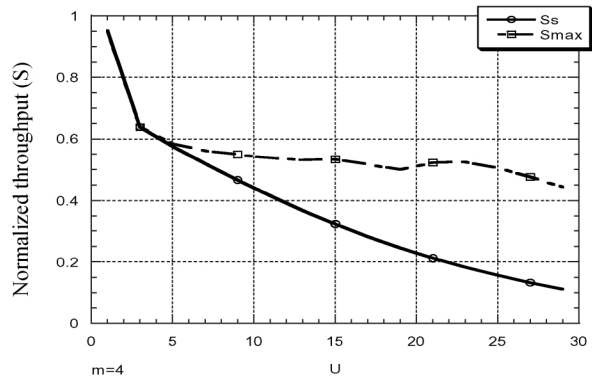
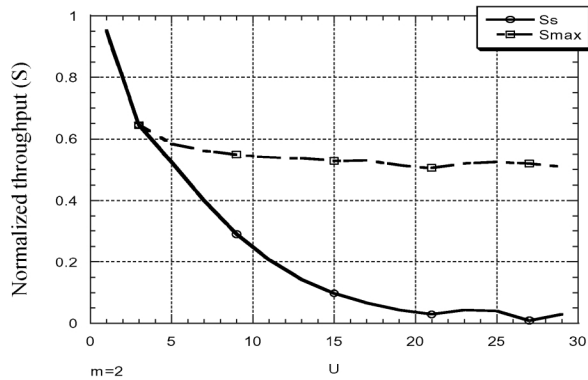

Fig. 16. Maximum throughput S_{max} and steady state throughput S_s against number of users U for $L = 100$ slots and different values of m .

rival. Looking at Fig. 10 it is noticed that increasing the number of users enhances the throughput up to a certain value of probability of arrival after which it the throughput decreases. To combine these two figures in a comprehensive graph, Fig. 12 is plotted. In this figure, the delay is plotted against the throughput for different values of arrival rate and for different number of users. It is noticed that increasing the probability of arrival increases the throughput and the delay up to a certain value of through-

put. After this value the delay continues to increase while the throughput either settles or decreases then settles. It is also noticed that after a while the delay also settles and increasing probability of arrival changes neither throughput nor delay. This is observed in Fig. 12 by the fact that all the points overlap on the same spot and the curve line does not go any further. From Fig. 13 it is noticed that the probability of finding the channel busy reached high values with increasing both probability of arrival and number of

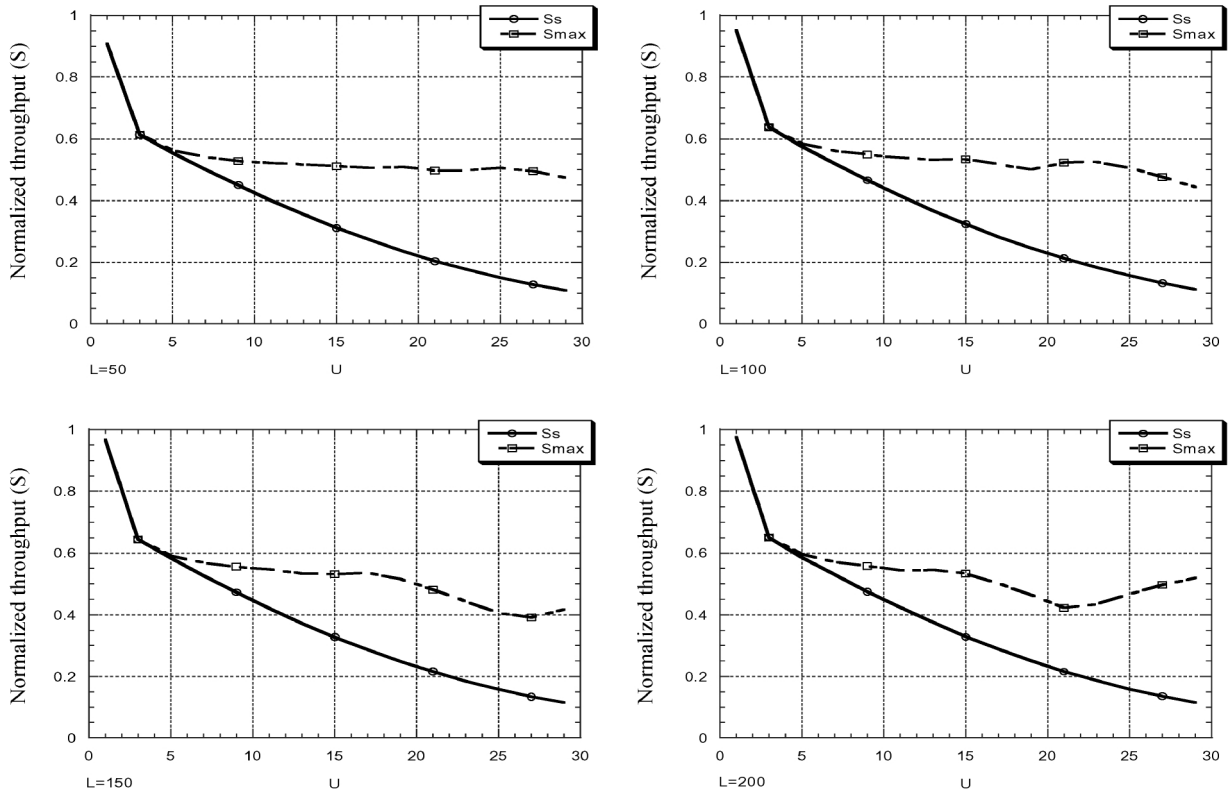

Fig. 17. Maximum throughput S_{max} and steady state throughput S_s against number of users U for $m = 4$ slots and different values of L .

users. This means that this protocol imposes large delay values at higher loads. This explains why the delay values are high in Fig. 11. It also implies that CSMA/CA is not suitable for time-bounded applications such as voice or video applications.

In Fig. 15, a three dimensional plot of the normalized throughput versus arrival rate and number of stations is given. It can be seen that for a number of retries equal to 2 the system performs adequately in terms of throughput for the number of stations up to 10 regardless of the value of the probability of arrival. Increasing the number of stations above this value increases the probability of collision hence decreases throughput remarkably.

To investigate the effect of increasing the number of retries Fig. 16 is plotted. In this figure S_{max} is the maximum achievable throughput for the given number of users U , packet length L , and maximum number of retries m . The maximization is done with respect to probability of arrival λ . It can be noticed that increasing m affects both the maximum and steady state throughput values remarkably and makes them converge to one another. On the other hand, in Fig. 17 increasing the packet length L slightly affects the maximum throughput values but does not result in making them asymptotically converge, nor does it affect the steady state value of throughput. This means that the major factor causing the steady state value of the throughput to differ from the maximum value is the operation of discarding colliding packets after a finite number of retransmissions.

7. Conclusions

Based on the above results and the associated comments the following conclusions are deduced:

1. CSMA/CA is a protocol suitable for low number of stations and low arrival rates (i.e. low offered traffic) which is expected for a contention-based access scheme.
2. The protocol has a large delay value that makes it unsuitable for time-bounded applications. This is why it is accompanied by another controlled access scheme in the IEEE 802.11 standards.
3. The value of the number of retries in the back-off scheme affects the protocol performance remarkably till a value of about 16 retries. Such value gives performance comparable to the case of infinite number of trials.
4. Using Single Station Superposition (SSS) technique with discrete time Markov analysis, we are able to establish a mathematical model for the performance parameters of a complicated protocol such as CSMA/CA. This model takes into consideration the effect of the random binary exponential back-off algorithm with finite number of retransmissions, which is an important feature of CSMA/CA. The numerical results from the analytical model were close to those produced by simulation, which indicates that the model produced has good accuracy.

References

- [1] William Stallings: Data and Computer Communications: 5th Edition. Prentice Hall, 1997.
- [2] Bruce Tuch: Development of WaveLAN: and ISM Band Wireless LAN. AT&T Technical Journal, pp. 27–37, Jul./Aug. 1993.
- [3] Jost Weinmiller, Morten Schlager, Andreas Festag, and Adam Wolisz: Performance Study of Access Control in Wireless LANs – IEEE 802.11 DFWMAC and ETSI RES 10 HIPERLAN. Work supported by a grant from the Deutsche Forschungs Gemeinschaft (DFG), for The Priority Program Mobile Communications.
[Http://www.tu-berlin.de/people/jost/pubs/](http://www.tu-berlin.de/people/jost/pubs/)
- [4] Harshal S. Chhaya: Performance Evaluation of the IEEE 802.11 MAC Protocol for Wireless LANs. M.Sc. Thesis, Illinois Institute of Technology, May 1996.
- [5] M.E. Woodward: Equivalence of Approximation Techniques for Solution of Multidimensional Markov Chains in Network Modeling. Electronic Letters 27, No. 12 (1991), pp. 1019–1021, 6th Jun. 1991.
- [6] Michael E. Woodward: Communication and Computer Networks modeling with discrete time queues. Pentech Press, 1993.
- [7] Tamer Khattab: Performance Analysis of Wireless Local Area Networks. M.Sc. thesis, Cairo Univ. Faculty of Engineering, Jan. 2000.



Tamer M.S. Khattab received his B.Sc. and M.Sc. in Electrical Engineering from Cairo University (Egypt) in 1993 and 2000, respectively. He is currently studying towards his Ph.D. in Electrical Engineering at the University of British Columbia (Canada). Since 1994 Eng. Khattab has been working as a Research and Teaching Assistant at the National Telecommunication Institute (Egypt). Also, during the period 1994–

1999 Eng. Khattab was involved with IBM Egypt in development projects for IBM corporate tools. Since Feb. 2000 Eng. Khattab

has been involved with Alcatel Canada in the Network and Service Management R&D department.



Mahmoud T. El-Hadidi received his B.Sc. and M.Sc. in Electrical Engineering from Cairo University (Egypt) in 1973 and 1975, respectively. He received his M.A. and Ph.D. in Electrical Engineering from Princeton University (USA) in 1977 and 1979, respectively. During the period 1979–1980, he was a visiting researcher at the Central Research Laboratories (C&C) of NEC (Japan), pursuing research in optical receivers for optical fiber communi-

cation systems. His research results led to two Japanese patents. While on leave of absence from Cairo University at Qatar University –from 1985 to 1992– Dr. El-Hadidi has initiated the work on a campus-wide local area network for Qatar University. After returning to Egypt in 1992, he has been active in the area of computer networks and pioneered the work on a nationwide computer network for the automation and inter-networking of Engineering Libraries in Egyptian Universities.

Dr. El-Hadidi holds the position of Professor of Computer Communication at the Department of Electronics and Electrical Communication at Cairo University since 1992. His current research interests include modelling and analysis of local area networks, congestion control in ATM networks, multimedia communication, LAN Interconnection via ATM Networks, wireless communication, and computer network security.



Hebat-Allah M. Mourad received her B.Sc., M.Sc. and Ph.D. degrees in Electrical Communication Engineering from Cairo University, Egypt, in 1983, 1987 and 1994 respectively. Since 1983, she has been with the Department of Electronics and Communications, Faculty of Engineering, Cairo University, and is currently assistant professor there. Her research interests include optical fiber communications, mobile and satellite communications.